

V680 Series

Amplifiers, Antennas, and ID Tags (FRAM)

USER'S MANUAL

OMRON

Introduction

Thank you for purchasing a V680-series RFID System. This manual describes the functions, performance, and application methods needed for optimum use of the V680-series RFID System.

Please observe the following items when using the RFID System.

- Allow the RFID System to be installed and operated only by qualified specialist with a sufficient knowledge of electrical systems.
- Read and understand this manual before attempting to use the RFID System and use the RFID System correctly.
- Keep this manual in a safe and accessible location so that it is available for reference when required.

Introduction	READ AND UNDERSTAND THIS DOCUMENT	Introduction
Section 1	Product Overview	Section 1
Section 2	Specifications and Performance	Section 2
Section 3	Communications Specifications	Section 3
Section 4	Installation	Section 4
Section 5	Chemical Resistance	Section 5

RFID System

V680-HA63B	Amplifier
V680-HS52	Antenna
V680-HS63	Antenna
V680-D2KF52M	ID Tag
V680-D2KF67	ID Tag
V680-D2KF67M	ID Tag
V680-D8KF68	ID Tag
V680-D32KF68	ID Tag

User's Manual

READ AND UNDERSTAND THIS DOCUMENT

Please read and understand this document before using the products. Please consult your OMRON representative if you have any questions or comments.

WARRANTY

OMRON's exclusive warranty is that the products are free from defects in materials and workmanship for a period of one year (or other period if specified) from date of sale by OMRON.

OMRON MAKES NO WARRANTY OR REPRESENTATION, EXPRESS OR IMPLIED, REGARDING NON-INFRINGEMENT, MERCHANTABILITY, OR FITNESS FOR PARTICULAR PURPOSE OF THE PRODUCTS. ANY BUYER OR USER ACKNOWLEDGES THAT THE BUYER OR USER ALONE HAS DETERMINED THAT THE PRODUCTS WILL SUITABLY MEET THE REQUIREMENTS OF THEIR INTENDED USE. OMRON DISCLAIMS ALL OTHER WARRANTIES, EXPRESS OR IMPLIED.

LIMITATIONS OF LIABILITY

OMRON SHALL NOT BE RESPONSIBLE FOR SPECIAL, INDIRECT, OR CONSEQUENTIAL DAMAGES, LOSS OF PROFITS OR COMMERCIAL LOSS IN ANY WAY CONNECTED WITH THE PRODUCTS, WHETHER SUCH CLAIM IS BASED ON CONTRACT, WARRANTY, NEGLIGENCE, OR STRICT LIABILITY.

In no event shall responsibility of OMRON for any act exceed the individual price of the product on which liability is asserted.

IN NO EVENT SHALL OMRON BE RESPONSIBLE FOR WARRANTY, REPAIR, OR OTHER CLAIMS REGARDING THE PRODUCTS UNLESS OMRON'S ANALYSIS CONFIRMS THAT THE PRODUCTS WERE PROPERLY HANDLED, STORED, INSTALLED, AND MAINTAINED AND NOT SUBJECT TO CONTAMINATION, ABUSE, MISUSE, OR INAPPROPRIATE MODIFICATION OR REPAIR.

SUITABILITY FOR USE

THE PRODUCTS CONTAINED IN THIS DOCUMENT ARE NOT SAFETY RATED. THEY ARE NOT DESIGNED OR RATED FOR ENSURING SAFETY OF PERSONS, AND SHOULD NOT BE RELIED UPON AS A SAFETY COMPONENT OR PROTECTIVE DEVICE FOR SUCH PURPOSES. Please refer to separate catalogs for OMRON's safety rated products.

OMRON shall not be responsible for conformity with any standards, codes, or regulations that apply to the combination of products in the customer's application or use of the product.

At the customer's request, OMRON will provide applicable third party certification documents identifying ratings and limitations of use that apply to the products. This information by itself is not sufficient for a complete determination of the suitability of the products in combination with the end product, machine, system, or other application or use.

The following are some examples of applications for which particular attention must be given. This is not intended to be an exhaustive list of all possible uses of the products, nor is it intended to imply that the uses listed may be suitable for the products:

- Outdoor use, uses involving potential chemical contamination or electrical interference, or conditions or uses not described in this document.
- Nuclear energy control systems, combustion systems, railroad systems, aviation systems, medical equipment, amusement machines, vehicles, safety equipment, and installations subject to separate industry or government regulations.
- Systems, machines, and equipment that could present a risk to life or property.

Please know and observe all prohibitions of use applicable to the products.

NEVER USE THE PRODUCTS FOR AN APPLICATION INVOLVING SERIOUS RISK TO LIFE OR PROPERTY WITHOUT ENSURING THAT THE SYSTEM AS A WHOLE HAS BEEN DESIGNED TO ADDRESS THE RISKS, AND THAT THE OMRON PRODUCT IS PROPERLY RATED AND INSTALLED FOR THE INTENDED USE WITHIN THE OVERALL EQUIPMENT OR SYSTEM.

PERFORMANCE DATA

Performance data given in this document is provided as a guide for the user in determining suitability and does not constitute a warranty. It may represent the result of OMRON's test conditions, and the users must correlate it to actual application requirements. Actual performance is subject to the OMRON Warranty and Limitations of Liability.

CHANGE IN SPECIFICATIONS

Product specifications and accessories may be changed at any time based on improvements and other reasons.

It is our practice to change model numbers when published ratings or features are changed, or when significant construction changes are made. However, some specifications of the product may be changed without any notice. When in doubt, special model numbers may be assigned to fix or establish key specifications for your application on your request. Please consult with your OMRON representative at any time to confirm actual specifications of purchased products.

DIMENSIONS AND WEIGHTS

Dimensions and weights are nominal and are not to be used for manufacturing purposes, even when tolerances are shown.

ERRORS AND OMISSIONS

The information in this document has been carefully checked and is believed to be accurate; however, no responsibility is assumed for clerical, typographical, or proofreading errors, or omissions.

PROGRAMMABLE PRODUCTS

OMRON shall not be responsible for the user's programming of a programmable product, or any consequence thereof.

COPYRIGHT AND COPY PERMISSION

This document shall not be copied for sales or promotions without permission. This document is protected by copyright and is intended solely for use in conjunction with the product. Please notify us before copying or reproducing this document in any manner, for any other purpose. If copying or transmitting this document to another, please copy or transmit it in its entirety.

Safety Precautions

Alert Symbols for Safe Use

The following symbols are used in this manual to indicate precautions that must be observed to ensure safe use of the V680-HS63, V680-HS52, V680-HA63B, V680-D2KF67, V680-D2KF67M, V680-D2KF52M, V680-D8KF68, and V680-D32KF68. The precautions provided here contain important safety information. Be sure to observe these precautions.

The following signal words are used in this manual.



Indicates a potentially hazardous situation which, if not avoided, will result in minor or moderate injury, or may result in serious injury or death. Additionally, there may be significant property damage.

Meanings of Alert Symbols



Indicates general prohibitions for which there is no specific symbol.

Warning



These Products are not designed to be used either directly or indirectly in applications that detect human presence for the purpose of maintaining safety. Do not use these Products as a sensing means for protecting human lives.

Regulations and Standards

The V680-HS63, V680-HS52, and V680-HA63B conform to the following overseas regulations and standards.

1. FCC Rules (Federal Communications Commission)
This product complies with Part 15 Subpart C of the FCC Rules.
FCC ID: E4E6CYSIDV6800306

FCC NOTICE

This device complies with part 15 of the FCC Rules. Operation is subject to the following two conditions:

- (1) This device may not cause harmful interference.
- (2) This device must accept any interference received, including interference that may cause undesired operation.

FCC WARNING

Changes or modifications not expressly approved by the party responsible for compliance could void the user's authority to operate the equipment.

Do not remove the ferrite core (TDK Type ZCAT1730-0730A) installed on the cables to suppress RF interference.

2. EC Declaration of Conformity

Hereby, OMRON Corporation declares that this RFID System, Antenna V680-HS52, V680-HS63, and Amplifier V680-HA63B. Amplifier and Antenna are in compliance with essential requirements and other relevant provisions of Directive 1995/5/EC, and satisfy tests for the appropriate requirements of the following relevant standards.

Radio: EN 300 330-2V1.1.1 (06-2001)
 EN 300 330-1V1.3.2 (12-2002)
 EMC: EN 301 489-3V1.4.1 (08-2002)
 EN 301 489-1V1.5.1 (11-2004)
 Safety: EN 61010-1: 2001 (2nd Edition)



English	Hereby, Omron, declares that the RFID System, V680-HS52 Series, V680-HS63 Series, and V680-HA63B Series are in compliance with the essential requirements and other relevant provisions of Directive 1999/5/EC.
Finnish	Omron vakuuttaa täten että RFID Säännös, V680-HS52 Series, V680-HS63 Series, V680-HA63B Series tyypinen laite on direktiivin 1999/5/EY oleellisten vaatimusten ja sitä koskevien direktiivin muiden ehtojen mukainen.
Dutch	Hierbij verklaart Omron dat het toestel de RFID Systeem, V680-HS52 'Serie, V680-HS63 'Serie, V680-HA63B 'Serie in overeenstemming is met de essentiële eisen en de andere relevante bepalingen van richtlijn 1999/5/EG.
French	Par la présente Omron déclare que la RFID Système, V680-HS52 Série, V680-HS63 Série, V680-HA63B Série sont conforme aux exigences essentielles et aux autres dispositions pertinentes de la directive 1999/5/CE.
Swedish	Härmed intygar Omron att den RFID System, V680-HS52 Serie, V680-HS63 Serie, V680-HA63B Serie står i överensstämmelse med de väsentliga egen-skapskrav och övriga relevanta bestämmelser som framgår av direktiv 1999/5/EG.
Danish	Undertegnede Omron erklærer herved, at følgende den RFID System, V680-HS52 Serie, V680-HS63 Serie, 680-HA63B Serie overholder de væsentlige krav og øvrige relevante krav i direktiv 1999/5/EF.
German	Hiermit erklart Omron, die RFID System, V670-H11 Serie, V680-HS63 Serie, V680-HA63B Serie in Übereinstimmung mit den grundlegenden Anforderungen und den anderen relevanten Vorschriften der Richtlinie 1999/5/EG befindet. (BMWi)
Greek	ΜΕ ΤΗΝ ΠΑΡΟΥΣΑ Οmron ΔΗΛΩΝΕΙ ΡFID ΟΥΟΓΗΜΑ, V680-HS52 ΟΕΙΡΑ, V680-HS63 ΟΕΙΡΑ, V680-HA63B ΟΕΙΡΑ SYMMOPF ONETAI ΠΙΡΟΣ ΤΙS ΟΥSΙΟΔΕΙS ΑΠΑΙΤΗSΕΙS ΚΑΙ ΤΙS ΛΟΗΤΕS SXETIKΕS ΔΙΑΤΑΞΕΙS ΤΗS ΟΔΗΓΙΑΣ 1999/5/ΕΚ.
Italian	Con la presente Omron dichiara che la RFID Sistema, V680-HS52Serie, V680-HS63 Serie, V680-HA63B Serie sono conforme ai requisiti essenziali ed alle altre disposizioni pertinenti stabilite dalla direttiva 1999/5/CE.
Spanish	Por medio de la presente Omron declara que el RFID Sistema, V680-HS52 Serie, V680-HS63 Serie, V680-HA63B Serie esta conforme a los requisitos esenciales y cualesquiera otras disposiciones aplicables o exigibles de la Directiva 1999/5/CE.
Portuguese	Omron declara que a RFID Sistema, V680-HS52 Série, V680-HS63 Série, V680-HA63B Série ser conforme com os tequisitos essenciais e outras disposiçōes da Directiva 1999/5/CE.
Romanian	Prin prezenta, Omron declară că acest V680-HS52, V680-HS63, V680-HA63 este conform cu cerințele principale și cu celelalte prevederi relevante ale Directivei 1999/5/EC.

Changes or modifications not expressly approved by the party responsible for compliance could void the user's authority to operate the equipment.

Do not remove the ferrite core (TDK Type ZCAT1730-0730A) installed on the cables to suppress RF interference.

3. Japan Radio Law

Equipment using high frequencies: Inductive Reading/Writing Communications Equipment

Conforming standards: Inductive Reading/Writing Communications Equipment; Standard: ARIB STD-T82

Precautions for Safe Use

Be sure to observe the following precautions to ensure safe use of the Products.

1. Do not use the Products in environments with flammable, explosive, or corrosive gasses.
2. Do not attempt to disassemble, repair, or modify any Product.
3. Tighten mounting screws securely.
4. If any cable has a locking mechanism, make sure that it has been locked before using the cable.
5. Do not allow water or pieces of wire to enter from openings in the case. Doing so may cause fire or electric shock.
6. Turn OFF the Controller power supply before mounting or removing an Antenna or Amplifier.
7. If an error is detected in any Product, immediately stop operation and turn OFF the power supply. Consult with an OMRON representative.
8. Dispose of the Products as industrial waste.
9. Observe all warnings and precautions given in the body of this manual.
10. Do not touch the product immediately after usage at high temperatures. Doing so may occasionally result in burning.

Precautions for Correct Use

Always observe the following precautions to prevent operation failures, malfunctions, and adverse effects on performance and equipment.

1. Installation Environment

Do not use the Products in the following locations.

- Locations exposed to corrosive gases, dust, metallic powder, or salts
- Locations not within the specified operating temperature range
- Locations subject to rapid changes in temperature or condensation
- Locations not within the specified humidity range
- Locations subject to direct vibration or shock outside the specified ranges
- Locations subject to spray of water, oil, or chemicals

2. Installation

The Products communicate with Tags using the 13.56-MHz frequency band. Some motors, inverters, and switching power supplies generate noise that can affect communications with the Tags and cause errors. If such devices are located near the Tags, always test operation in advance to confirm whether the system will be affected.

- Observe the following precautions to minimize the effects of normal noise.
 - (1) Ground all metal objects in the vicinity of the Products to 100 Ω or less.
 - (2) Do not use the Products near high-voltage or high-current lines.
- Do not use non-waterproof Products in an environment where mist is present.
- Do not expose the Products to chemicals that adversely affect the Product materials.
- When mounting the Products, tighten the screws to the following torques.
V680-HS63: 1.2 N·m
V680-HS52: 40 N·m
- Transmission will not be possible if the front and back panels are mistakenly reversed and the Unit is mounted to a metallic surface.
V680-D2KF67M
- The transmission distance will be reduced when the Unit is not mounted to a metallic surface.
V680-D2KF67M
- If multiple Antennas are mounted near each other, communications performance may decrease due to mutual interference. Refer to *Installing Antennas on page 42* and check to make sure there is no mutual interference.
- Depending on the operating environment, the case surface may become fogged, but basic performance will not be affected.

3. Storage

Do not store the Products in the following locations.

- Locations exposed to corrosive gases, dust, metallic powder, or salts
- Locations not within the specified storage temperature range
- Locations subject to rapid changes in temperature or condensation
- Locations not within the specified storage humidity range
- Locations subject to direct vibration or shock outside the specified ranges
- Locations subject to spray of water, oil, or chemicals

4. Cleaning

- Do not clean the Products with paint thinner or the equivalent. Paint thinner or the equivalent will dissolve the resin materials and case coating.

5. Combination of the Amplifier

Use the V680-D2KF67, V680-D2KF67M, V680-D2KF52M, V680-D8KF68, and V680-D32KF68 ID Tags in combination with only the V680-HA63B Amplifier. Do not use these ID Tags together with the V680-HA63A Amplifier.

Meanings of Symbols



Indicates particularly important points related to a function, including precautions and application advice.



Indicates page numbers containing relevant information.

Table of Contents

Safety Precautions	3
Regulations and Standards	3
Precautions for Safe Use	5
Precautions for Correct Use	6
Meanings of Symbols	8
Table of Contents	9
Section 1 Product Overview	11
Features	12
Product Configuration	13
Section 2 Specifications and Performance	15
Antennas with Separate Amplifier	16
Amplifier	20
Tags	23
Section 3 Communications Specifications	29
Communications Distances	30
TAT and Communication Time (Reference)	35
Section 4 Installation	41
Installing Antennas	42
Mounting Amplifiers	45
Installing Tags	47
Section 5 Chemical Resistance	55
Chemical Resistance of the Antennas	56
Chemical Resistance of Tags	57
Degree of Protection	60
Revision History	62

MEMO

Section 1

Product Overview

▣ Features	12
▣ Product Configuration	13

Features

The V680-series RFID System actively supports many different types of system, such as distributed-control systems and many-product, small-lot production systems, with non-contact data communications using electromagnetic induction.

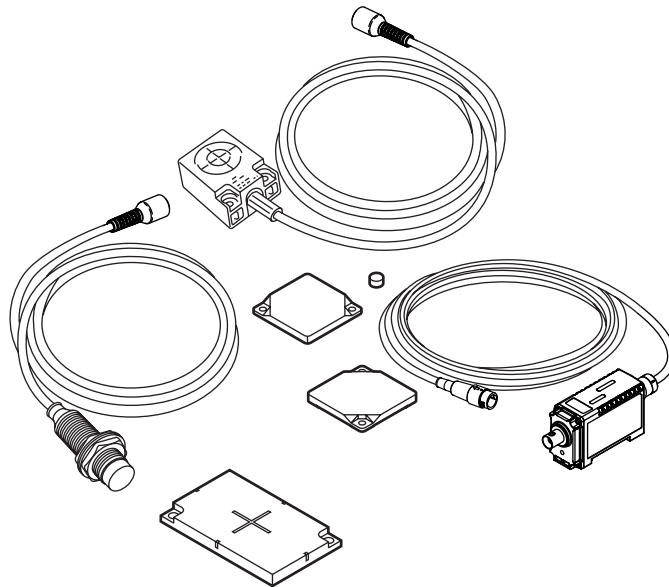

■ Non-contact Data Communications

The V680 Series uses electromagnetic induction to enable non-contact, bi-directional data communications between Antennas and Tags.

■ FRAM Memory

FRAM (non-volatile memory) is used for Tag memory. No battery is required, so there is no need to be concerned about battery service life.

■ CRC Used for Transmission Error Detection

A bi-directional 16-bit CRC (Cyclic Redundancy Check) has been added as the error detection method for wire transmissions between ID Controllers and Antennas, and for wireless transmissions between Antennas and Tags. This method maintains superior communications reliability even where problems such as noise occur.

■ Memory Capacity of 2,000, 8,192, or 32,744 Bytes

Tags have a memory capacity of 2,000, 8,192, or 32,744 bytes. In addition to the ID data required on-site, data such as model numbers and inspection information can be input.

■ Long service life: 10 billion accesses

The FRAM memory can be accessed up to 10 billion times (in units of single, 8-byte blocks)

■ Superior Environmental Resistance and High Reliability

Antennas and Tags now have greater environmental resistance and are not affected by vibration, oil, or water.

Product Configuration

A V680-series RFID System consists of an ID Controller, one or more Amplifiers, one or two Antennas, and Tags. Select the models suitable for the application.

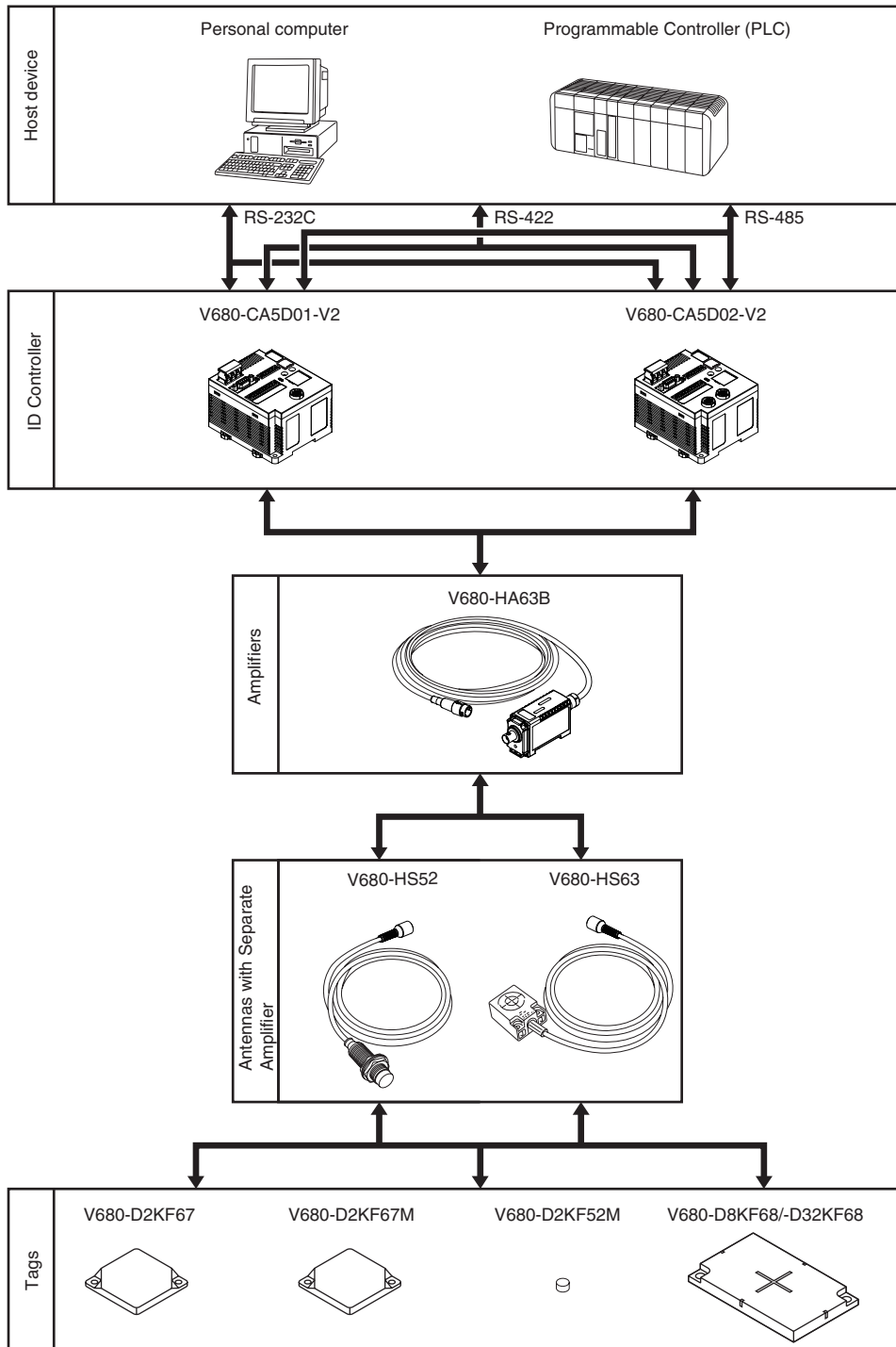

When embedding the V680-D2KF52M into a metal surface, use the V680-HS52 Antenna. Transmission will not be possible if the V680-HS63 Antenna is used.



Use the V680-D2KF67, V680-D2KF67M, V680-D2KF52M, V680-D8KF68, and V680-D32KF68 ID Tags in combination with only the V680-HA63B Amplifier. Do not use these ID Tags together with the V680-HA63A Amplifier.

MEMO

Section 2

Specifications and Performance

☒ Antennas with Separate Amplifier	16
☒ Amplifier	20
☒ Tags	23

Antennas with Separate Amplifier

V680-HS63

General Specifications

Item	Model	V680-HS63-W (Standard cable, waterproof connector)	V680-HS63-R (Flexible cable, non-waterproof connector)
Ambient operating temperature		-10 to 60°C (with no icing)	
Ambient storage temperature		-25 to 75°C (with no icing)	
Ambient operating humidity		35% to 95% (with no condensation)	
Insulation resistance		20 MΩ min. (at 500 VDC) between cable terminals and case	
Dielectric strength		1,000 VAC, 50/60Hz for 1 min between cable terminals and case	
Degree of protection		In-house standard for antenna oil resistance (former JEM standard equivalent to IP67g) Note: The connector specifications are IP67 and IP65 (IEC 60529).	In-house standard for antenna oil resistance (former JEM standard equivalent to IP67g) Note: The connectors are not waterproof.
Vibration resistance		10 to 500 Hz, 1.5-mm double amplitude, acceleration: 100 m/s ² , 10 sweeps in each of 3 axis directions (up/down, left/right, and forward/backward) for 11 minutes each	
Shock resistance		500 m/s ² , 3 times each in 6 directions (Total: 18 times)	
Dimensions		40 × 53 × 23 mm	
Material		ABS resin case, epoxy resin filler	
Weight		Approx. 850 g (with 12.5 m cable)	
Cable length		Standard lengths of 2 and 12.5 m	

Dimensions

V680-HS63-W

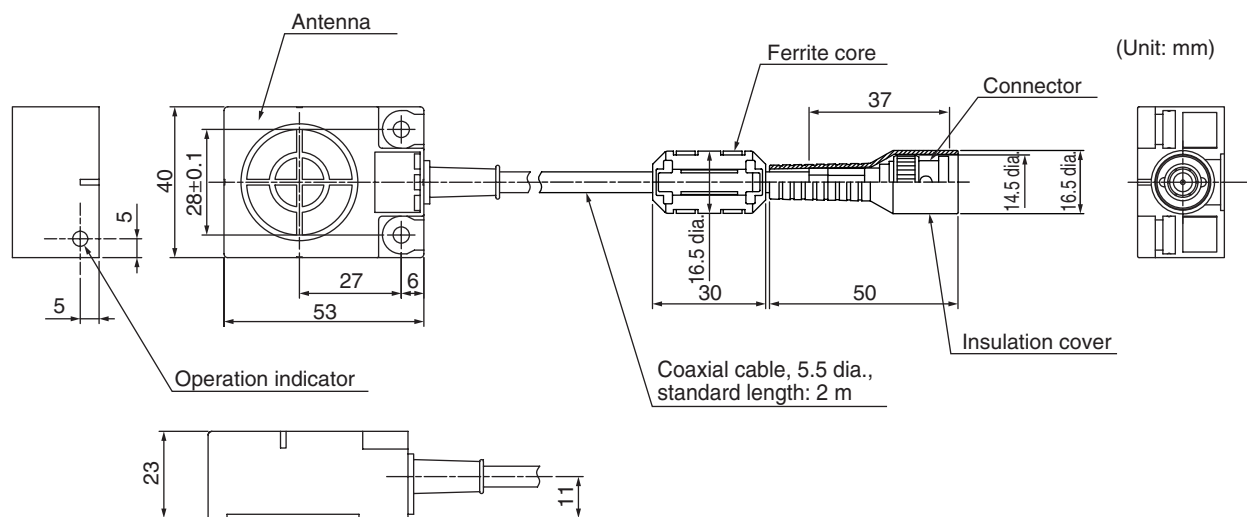

Note: Mounting Hole Dimensions

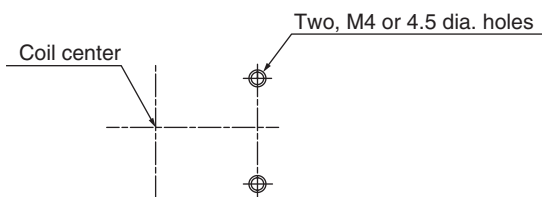

Case material	ABS resin
Fill resin	Epoxy resin
Cable	PVC (gray)

• V680-HS63-R

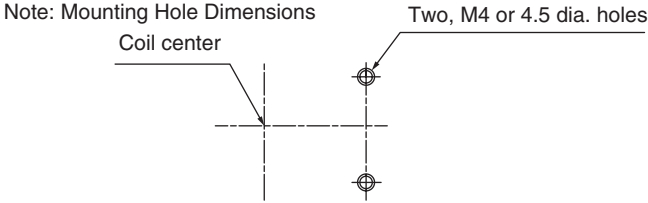
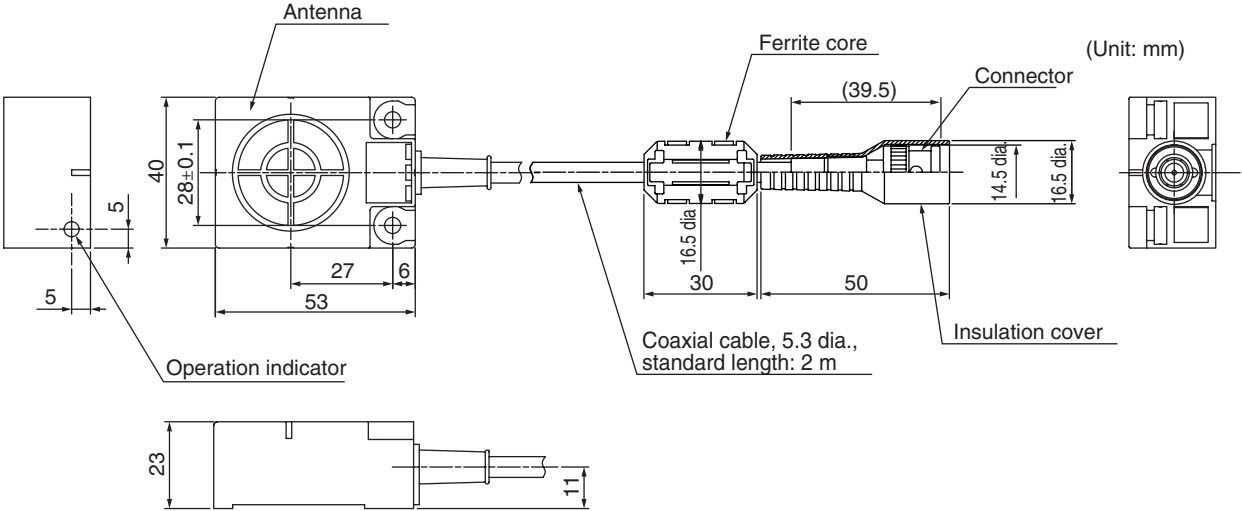

Case material	ABS resin
Fill resin	Epoxy resin
Cable	PVC (black)

V680-HS52

General Specifications

Item	Model	V680-HS52-W (Standard cable, waterproof connector)	V680-HS52-R (Flexible cable, non-waterproof connector)
Ambient operating temperature		-10 to 60°C (with no icing)	
Ambient storage temperature		-25 to 75°C (with no icing)	
Ambient operating humidity		35% to 95% (with no condensation)	
Insulation resistance		20 MΩ min. (at 500 VDC) between connector terminals and case	
Dielectric strength		1,000 VAC, 50/60 Hz for 1 min between connector terminals and case	
Degree of protection		In-house standard for antenna oil resistance (former JEM standard equivalent to IP67g) Note: The connector specifications are IP67 and IP65 (IEC 60529).	In-house standard for antenna oil resistance (former JEM standard equivalent to IP67g) Note: The connectors are not waterproof.
Dielectric strength		10 to 500 Hz, 1.5-mm double amplitude, acceleration: 100 m/s ² , 10 sweeps in each of 3 axis directions (up/down, left/right, and forward/backward) for 8 minutes each	
Shock resistance		500 m/s ² , 3 times each in 6 directions (Total: 18 times)	
Dimensions		M22 × 65 mm	
Material		ABS resin, brass, and epoxy resin filler	
Weight		Approx. 850 g (with 12.5 m cable)	
Cable length		Standard lengths of 2 and 12.5 m	

Dimensions

• V680-HS52-W

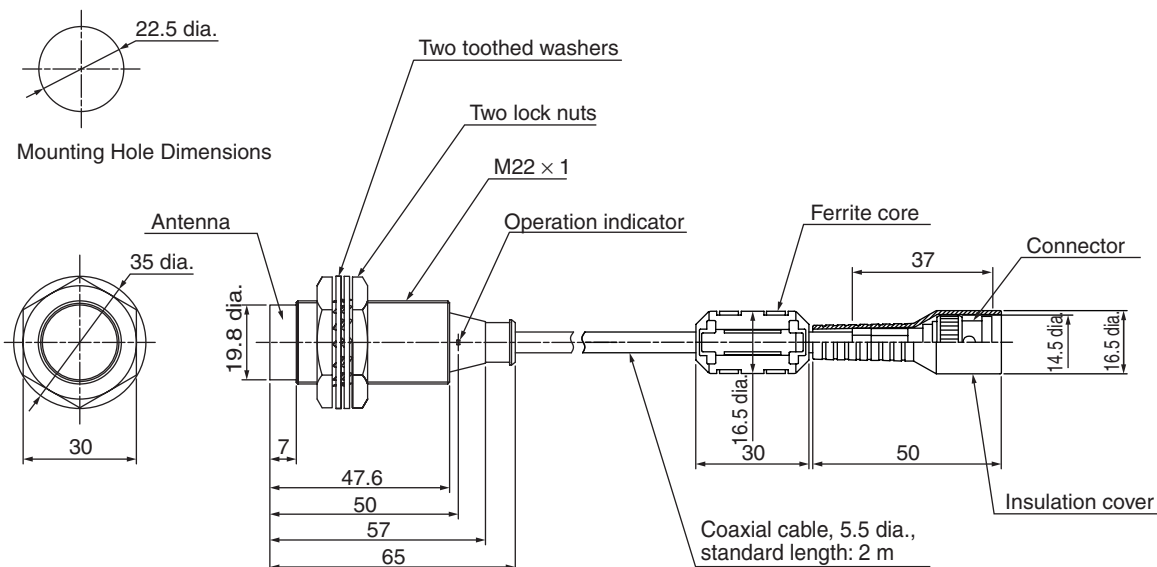

Case material	Brass
Communications surface	ABS resin
Fill resin	Epoxy resin
Cable	PVC (gray)

• V680-HS52-R

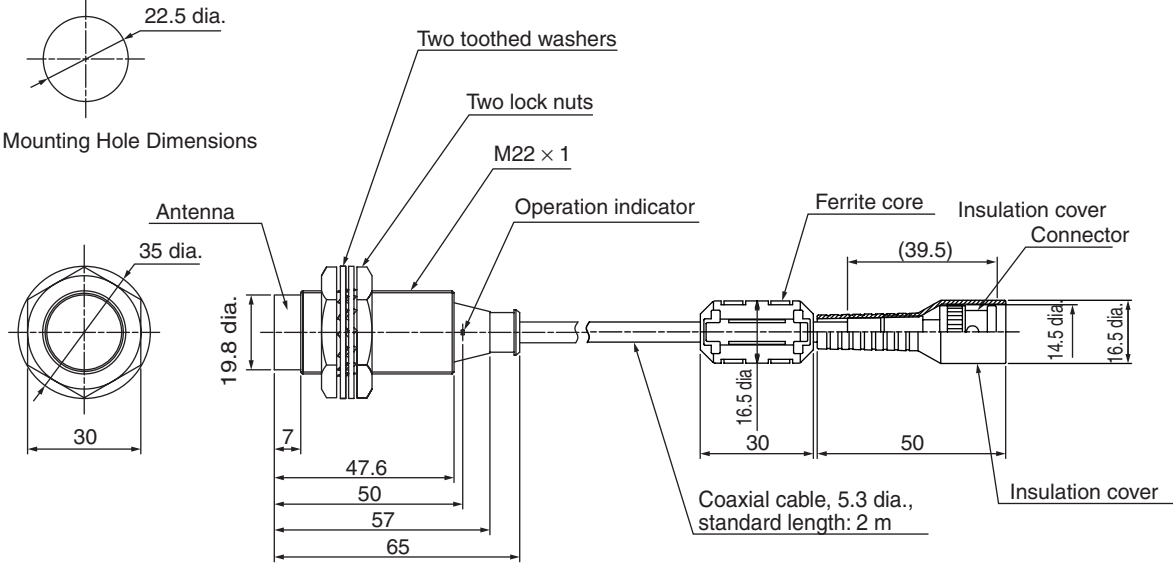

Case material	Brass
Communications surface	ABS resin
Fill resin	Epoxy resin
Cable	PVC (black)

Amplifier

V680-HA63B

General Specifications

Item	Model	V680-HA63B
Ambient operating temperature		-10 to 55°C (with no icing)
Ambient storage temperature		-25 to 65°C (with no icing)
Ambient operating humidity		35% to 85% (with no condensation)
Insulation resistance		20 MΩ min. (at 500 VDC) between cable terminals and case
Dielectric strength		1,000 VAC, 50/60 Hz for 1 minute between cable terminals and case.
Degree of protection		IP67, IP65 (IEC 60529) Note: Not including connector at Controller end. (When V680-HS63-W or V680-HS52-W is connected)
		IP40 (IEC 60529) (When V680-HS63-R or V680-HS52-R is connected)
Dielectric strength		10 to 500 Hz, 1.5-mm double amplitude, acceleration:100 m/s ² , 10 sweeps in each of 3 axis directions (up/down, left/right, and forward/backward) for 11 minutes each
Shock resistance		500 m/s ² , 3 times each in 6 directions (Total: 18 times)
Dimensions		25 × 40 × 65 mm (Not including protrusions.)
Materials		PC
Weight		Approx. 850 g (with 10 m cable)
Cable length		Standard lengths of 5 and 10 m

Note: The maximum total cable extension is 50 m (including the Amplifier cable). A maximum of two extension cables can be connected.

Dimensions

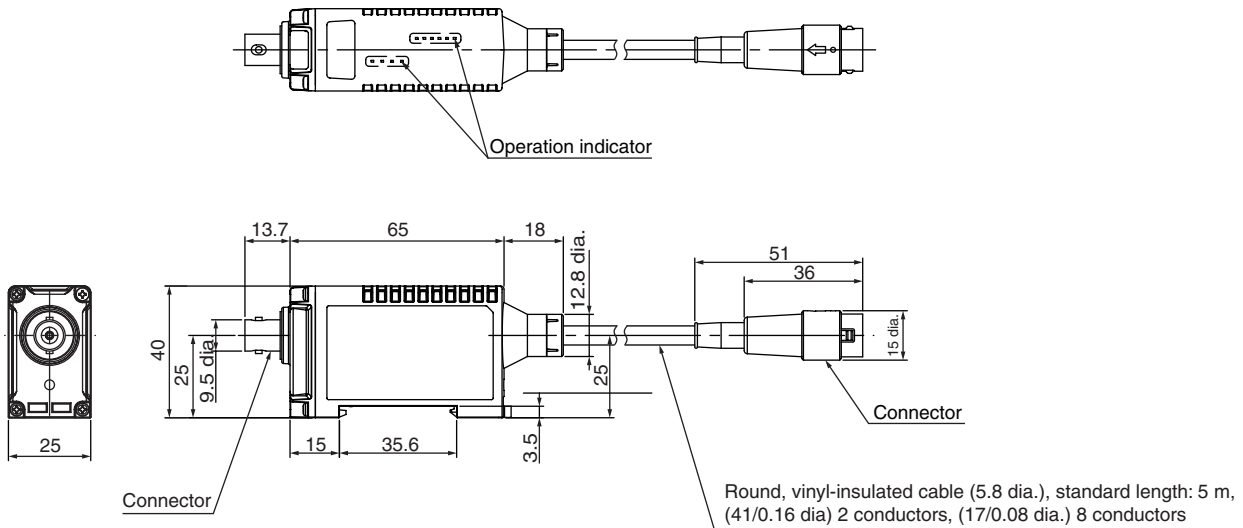

Case material	PC resin
Cable	PVC

Nomenclature

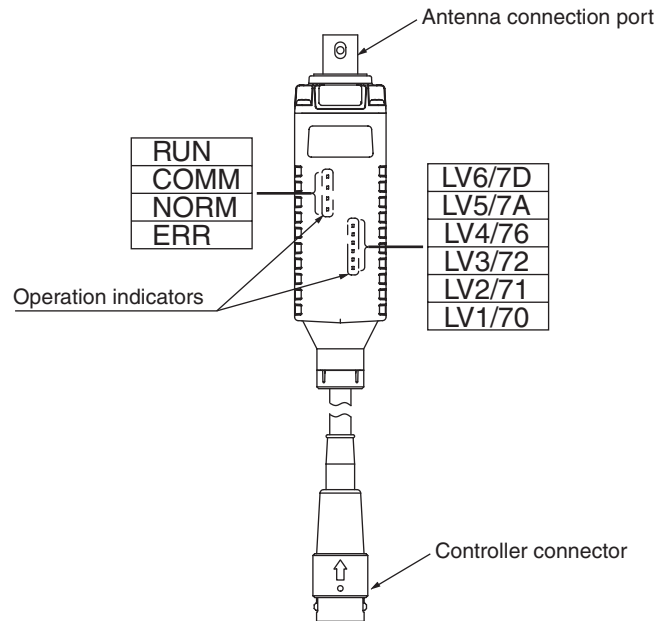

■ Antenna Connection Port

The Antenna connection port is connected a V680-series Antenna.

■ Controller Connector

The Controller connector is connected to Antenna connection port on the Controller.

■ Operation Indicators (LEDs)

Name	Color	Meaning
RUN	Green	Lit when the power is ON.
COMM	Yellow	Lit when a command is being sent.
NORM	Green	Lit when communications with a Tag are normal in Normal Communications Mode.
ERR	Red	Lit when an error occurs in communications with a Tag in Normal Communications Mode.
LV6/7D	Yellow	Maintenance Mode: Lit at distance or speed level 6. Normal Communications Mode: Lit when a write protection error occurs.
LV5/7A	Yellow	Maintenance Mode: Lit at distance or speed level 5 or higher. Normal Communications Mode: Lit when an address error occurs.
LV4/76	Yellow	Maintenance Mode: Lit at distance or speed level 4 or higher. Normal Communications Mode: Lit when a Tag memory error occurs.
LV3/72	Yellow	Maintenance Mode: Lit at distance or speed level 3 or higher. Normal Communications Mode: Lit when a no Tag error occurs.
LV2/71	Yellow	Maintenance Mode: Lit at distance or speed level 2 or higher. Normal Communications Mode: Lit when a verification error occurs.
LV1/70	Yellow	Maintenance Mode: Lit at distance or speed level 1 or higher. Normal Communications Mode: Lit when a Tag communications error occurs.



The distance level will vary greatly depending on the surrounding environment. The setting position will serve as a guide, but use RUN mode to conduct a sufficient number of tests in the actual operating environment. Values of distance level 4 or above may not be displayed, but this will not affect the RUN mode performance and does not indicate a malfunction.

Cables

Specifications

Item	Model	V700-A43/V700-A44
Number of conductors		10
Insulation resistance		5 MΩ min. (at 500 VDC) between terminals and sheath
Dielectric strength		500 VAC, 1 min

Dimensions

Item	Model	V700-A43	V700-A44
Length (L1)		Approx. 10m	Approx. 20 m
Weight		Approx. 700 g	Approx. 1,350 g

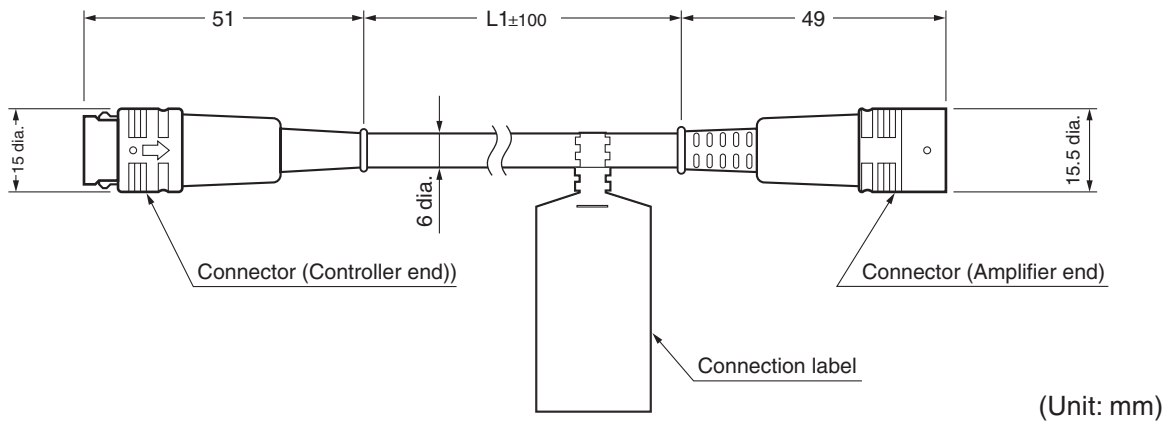

Casing material	PVC
-----------------	-----

Tags

Specifications and Dimensions

■ V680-D2KF52M

• General Specifications

Item	Model	V680-D2KF52M
Memory capacity		2,000 bytes (user area)
Memory type		FRAM
Data backup time		10 years after writing (55°C or less)
Memory longevity		10 billion times per address. Access frequency (See note) : 10 billion times
Ambient operating temperature		-25 to 85°C (with no icing)
Ambient storage temperature		-40 to 85°C (with no icing)
Ambient operating humidity		35% to 85%
Degree of protection		IP67 (IEC 60529)
Vibration resistance		10 to 2,000 Hz, 1.5-mm double amplitude, acceleration: 150 m/s ² , 10 sweeps each in X, Y, and Z directions for 15 minutes each
Shock resistance		500 m/s ² , 3 times each in X, Y, and Z directions (Total: 18 times)
Dimensions		8 dia. × 5 mm
Materials		Case: PPS resin, Fill resin: Epoxy resin
Weight		Approx. 0.5 g
Metal countermeasures		Yes

Note: The total communication frequency of the Read or Write is called an access frequency.

• Dimensions

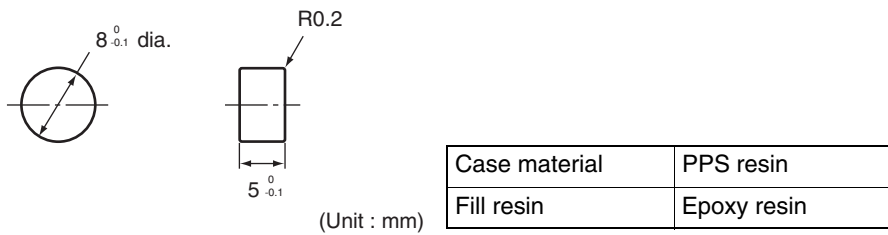

When embedding the V680-D2KF52M into a metal surface, use the V680-HS52 Antenna. Transmission will not be possible if the V680-HS63 Antenna is used.



The side with the markings is the communications surface. Mount the Tag with this side facing the Antenna.

■ V680-D2KF67/67M

• General Specifications

Item	Model	V680-D2KF67	V680-D2KF67M
Memory capacity		2,000 bytes (user area)	
Memory type		FRAM	
Data backup time		10 years after writing (55°C or less)	
Memory longevity		10 billion times per address. Access frequency (See note) : 10 billion times	
Ambient operating temperature		-25 to 85°C (with no icing)	
Ambient storage temperature		-40 to 85°C (with no icing)	
Ambient operating humidity		35% to 85%	
Degree of protection		IP67 (IEC 60529)	
Vibration resistance		10 to 2,000 Hz, 1.5-mm double amplitude, acceleration: 150 m/s ² , 10 sweeps each in X, Y, and Z directions for 15 minutes each	
Shock resistance		500 m/s ² , 3 times each in X, Y, and Z directions (Total: 18 times)	
Dimensions		40 × 40 × 4.5 mm	
Materials		Case: ABS resin	
Weight		Approx. 6.5 g	Approx. 7 g
Metal countermeasures		None	Yes

Note: The total communication frequency of the Read or Write is called an access frequency.

The V680-D2KF67M is designed to be mounted directly to metal. The V680-D2KF67 and V680-D2KF67M markings are shown in the following diagrams.

● V680-D2KF67M



● V680-D2KF67

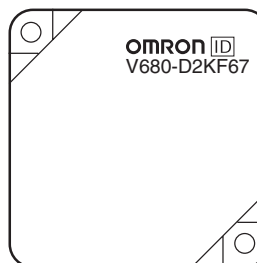

The side with the markings is the communications surface. Mount the Tag with this side facing the Antenna.

• Dimensions

V680-D2KF67/67M

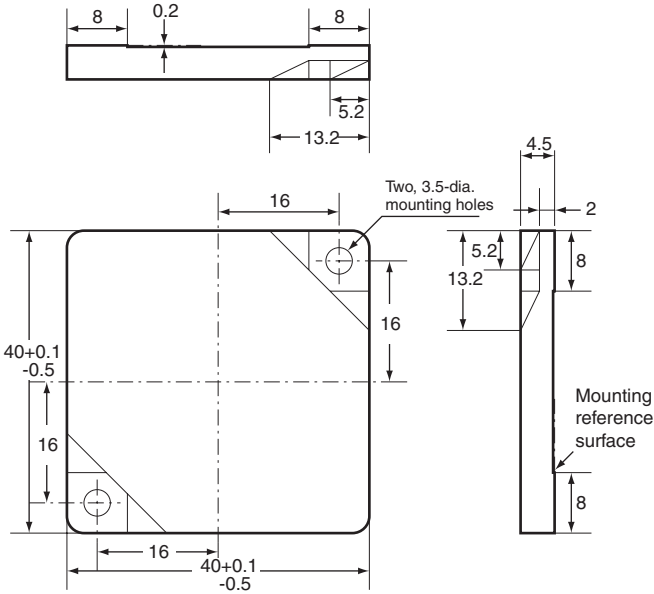

(Unit:mm)

Mounting Hole Dimensions

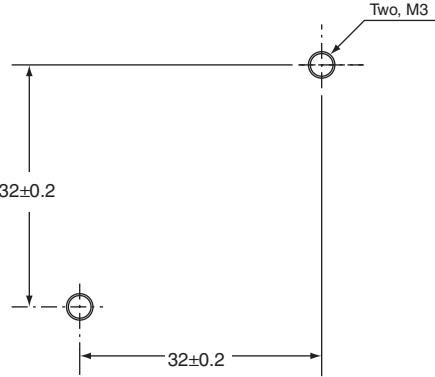

Case material	ABS resin
Fill resin	Epoxy resin

■ V680-D8KF68/-D32KF68

• General Specifications

Item	Model	V680-D8KF68	V680-D32KF68
Memory capacity		8,192 bytes (user area)	32,744 bytes (user area)
Memory type		FRAM	
Data backup time		10 years after writing (70°C max.), 6 years after writing (85°C max.)	
Memory longevity		10 billion times per address (85°C or less). Access frequency (See note): 10 billion times	
Ambient operating temperature		-20 to 85°C (with no icing)	
Ambient storage temperature		-40 to 85°C (with no icing)	
Ambient operating humidity		35% to 85%	
Degree of protection		IP67 (IEC 60529) In-house standard for oil resistance (former JEM standard equivalent to IP67g)	
Vibration resistance		10 to 500 Hz, 1.5-mm double amplitude, acceleration: 100 m/s ² , 10 sweeps each in X, Y, and Z directions for 11 minutes each	
Shock resistance		500 m/s ² , 3 times each in X, Y, and Z directions (Total: 18 times)	
Dimensions		86 × 54 × 10 mm	
Materials		Case: PBT resin Fill resin: Epoxy resin	
Weight		Approx. 50 g	
Metal countermeasures		None	

Note: The total communication frequency of the Read or Write is called an access frequency.

• Dimensions

V680-D2KF68/68M

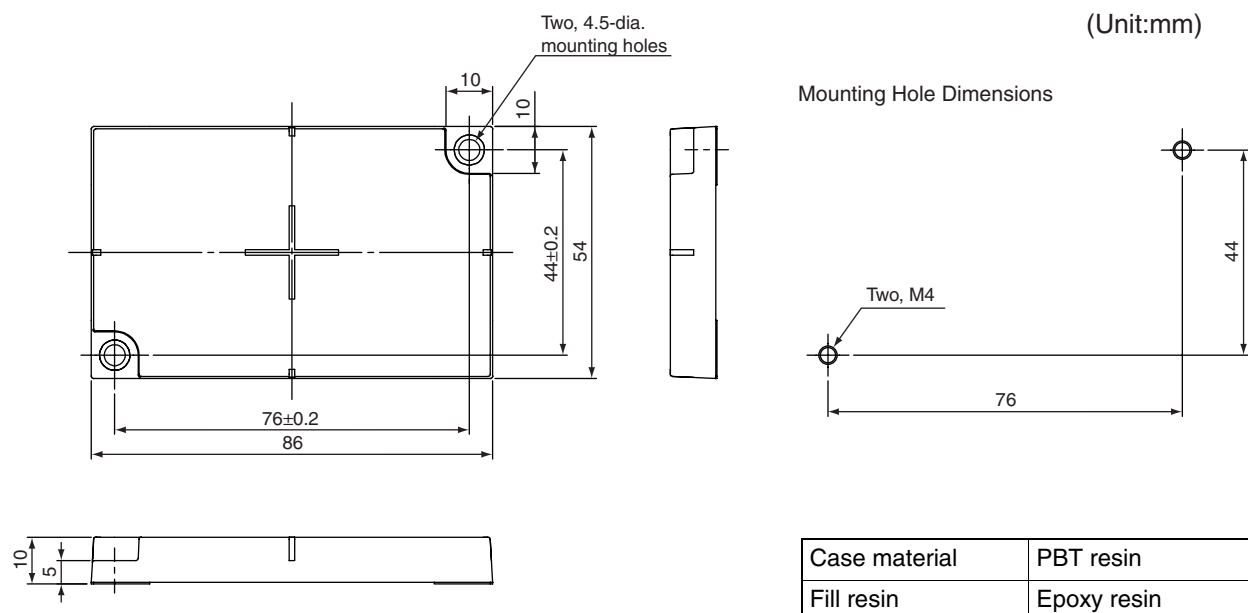

The side with the markings is the communications surface. Mount the Tag with this side facing the Antenna.

Memory Map

■ V680-D2KF52/-D2KF67/-D2KF67M

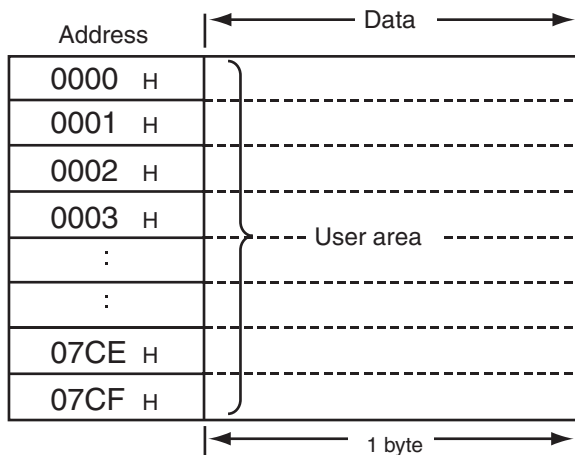

FRAM is used as memory in the Tags.
The memory capacity available to the user is 2,000 bytes, including 0000H to 0003H (the Write Protection Setting Area).

■ V680-D8KF68

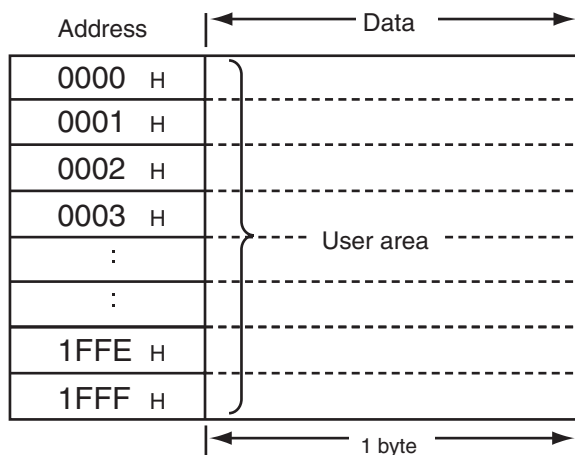

FRAM is used as memory in the Tags.
The memory capacity available to the user is 8,192 bytes, including 0000H to 0003H (the Write Protection Setting Area).

■ V680-D32KF68

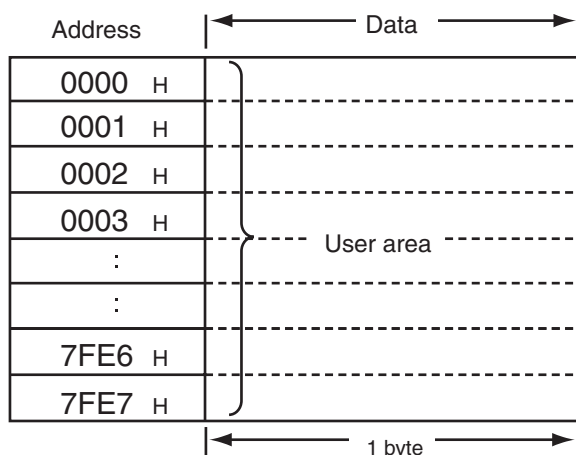

FRAM is used as memory in the Tags.
The memory capacity available to the user is 32,744 bytes, including 0000H to 0003H (the Write Protection Setting Area).

Write Protection Function

The write protection function prevents important data, such as product information, stored in memory in a Tag from being inadvertently overwritten.

After important data has been written to memory, it can be write-protected using the following method.



The write protect function setting can be switched with switches 4 to 7 (Write Protect Function Setting) of the V680-CA5D@@-V2 Controller.

CHECK!

Setting the Write Protection Function

Write protection is set in Tag addresses 0000H to 0003H.

The setting for the most significant bit of address 0000H specifies whether or not write protection is enabled.

Address	Bit	7	6	5	4	3	2	1	0
0000H	YES/ NO	Upper two digits of start address (00 to 7F)							
0001H		Lower two digits of start address (00to FF)							
0002H		Upper two digits of end address (00 to FF)							
0003H		Lower two digits of end address (00 to FF)							

- Write-protect Bit (Most significant bit of address 0000H)**

1: Write-protected (Yes)

0: Not write-protected (No)

- Write Protection Setting Area**

Start address: 0000H to 7FFFH

End address: 0000H to FFFFH

Write Protection Setting Examples

- Settings to write-protect addresses 0008H through 03E7H:

Address	Bit	7	6	5	4	3	2	1	0
0000H		1	0	0	0	0	0	0	0
		8				0			
0001H		0	0	0	0	1	0	0	0
		0				8			
0002H		0	0	0	0	0	0	1	1
		0				3			
0003H		1	1	1	0	0	1	1	1
		E				7			

- Settings to not write-protect any addresses:

Address	Bit	7	6	5	4	3	2	1	0
0000H		0	0	0	0	0	0	0	0
		0				0			
0001H		0	0	0	0	0	0	0	0
		0				0			
0002H		0	0	0	0	0	0	0	0
		0				0			
0003H		0	0	0	0	0	0	0	0
		0				0			



The write protect function is a function of the V680-CA5D@@-V2 Controller. This function is not supported by reader/writer units of other brands.

CHECK!

Section 3

Communications Specifications

☒ Communications Distances	30
☒ TAT and Communication Time (Reference)	35

Communications Distances

V680-D2KF52M

■ Communications Distance Specifications (Certified Performance)

Amplifier	Antenna	ID Tag	Communications distance	
V680-HA63B	V680-HS52	V680-D2KF52M	Read	0 to 8.0 mm (Axis offset: ± 2)
			Write	0 to 8.0 mm (Axis offset: ± 2)
	V680-HS52	V680-D2KF52M embedded in metal (steel)	Read	0 to 3.0 mm (Axis offset: ± 2)
			Write	0 to 3.0 mm (Axis offset: ± 2)
	V680-HS63	V680-D2KF52M	Read	0 to 9.5 mm (Axis offset: ± 2)
			Write	0 to 9.5 mm (Axis offset: ± 2)



When embedding the V680-D2KF52M into a metal surface, use the V680-HS52 Antenna. Transmission will not be possible if the V680-HS63 Antenna is used.

CHECK!

• Measurement Conditions

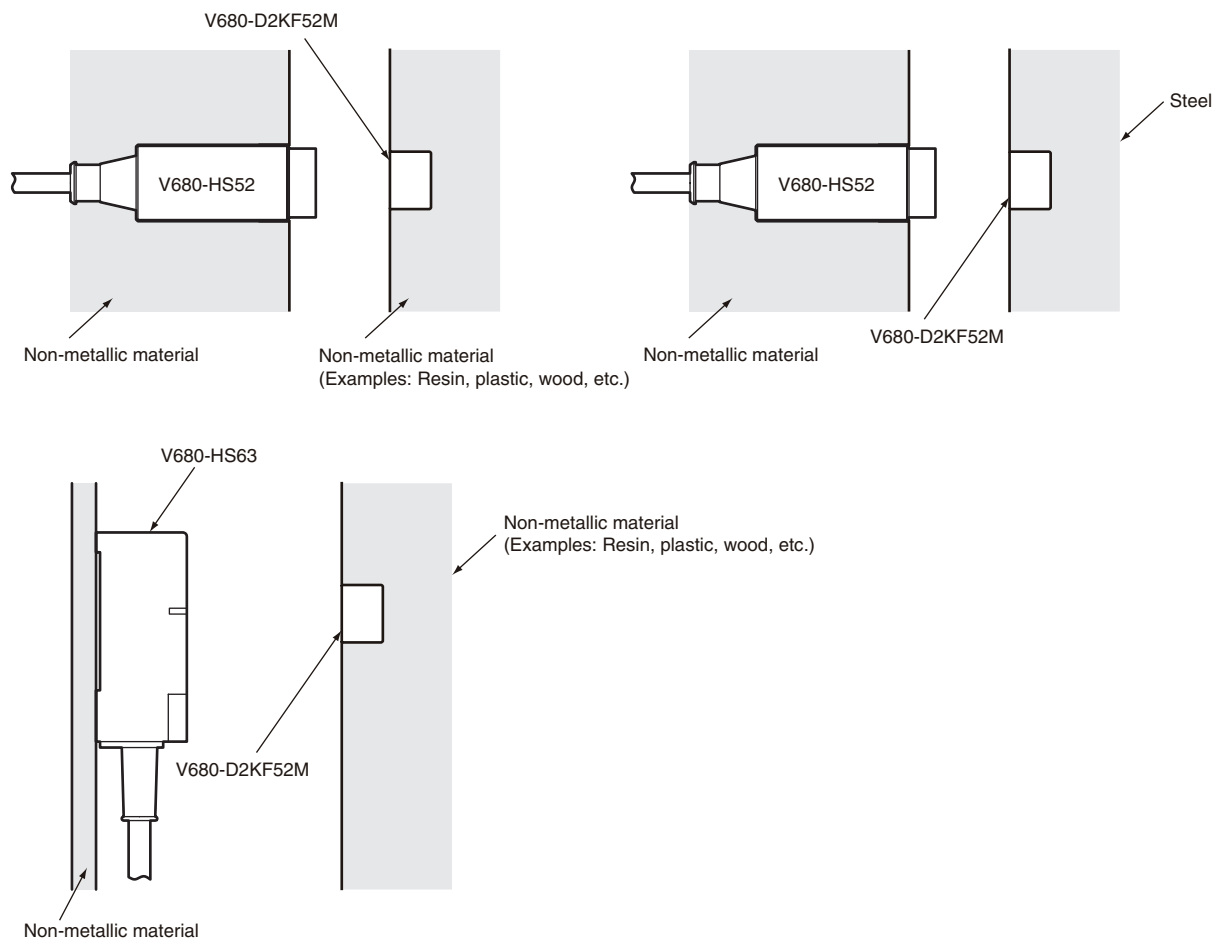

■ Communications Area (Reference)

● V680-HS52 & V680-D2KF52M

▪ Read/Write

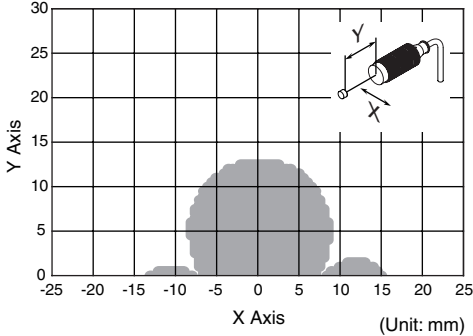

● V680-HS52 & V680-D2KF52M

Embedded in Metal (Steel)

▪ Read/Write

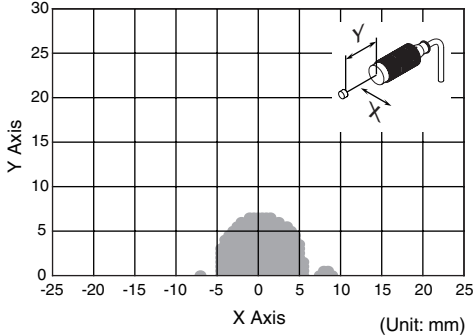

● V680-HS63 & V680-D2KF52M

▪ Read/Write

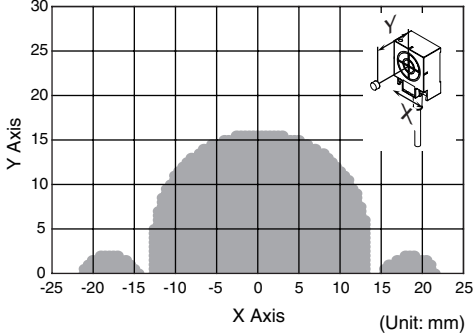

V680-D2KF67

■ Communications Distance Specifications (Certified Performance)

Amplifier	Antenna	ID Tag	Communications distance	
			Read	Write
V680-HA63B	V680-HS52	V680-D2KF67	Read	0 to 17.0 mm (Axis offset: ± 2)
			Write	0 to 17.0 mm (Axis offset: ± 2)
	V680-HS63	V680-D2KF67	Read	7.0 to 30.0 mm (Axis offset: ± 10)
			Write	7.0 to 30.0 mm (Axis offset: ± 10)

• Measurement Conditions

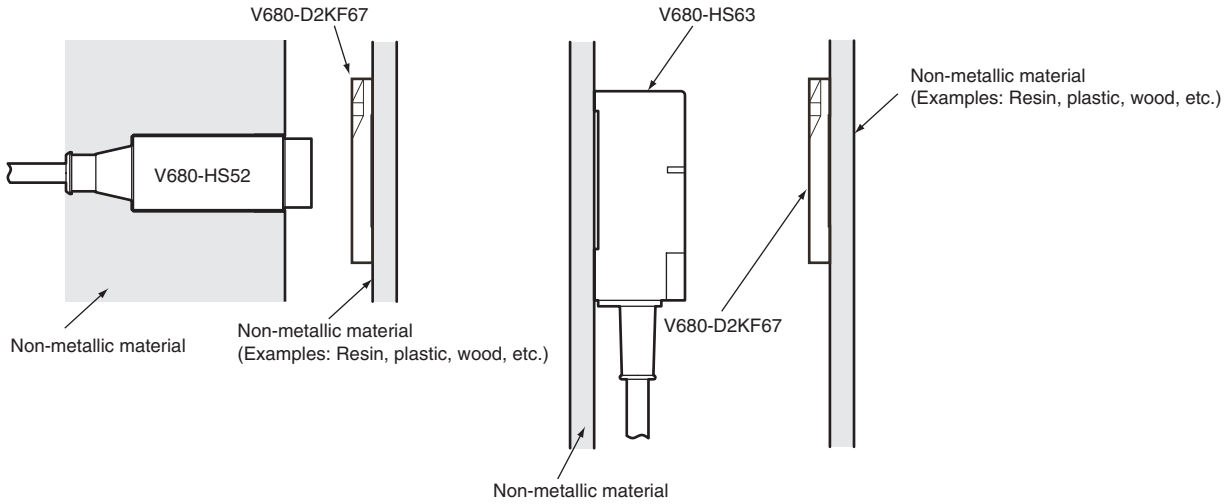

■ Communications Area (Reference)

● V680-HS52 & V680-D2KF67

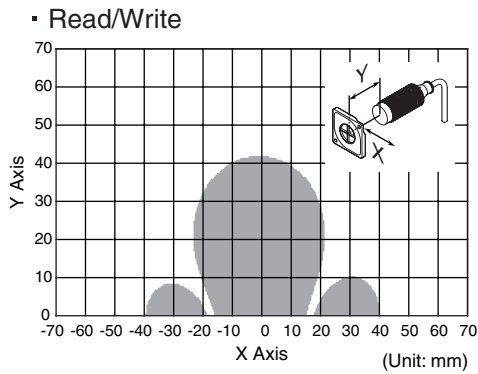

● V680-HS63 & V680-D2KF67

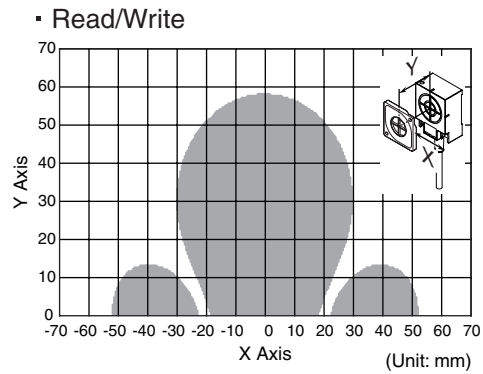

V680-D2KF67M

■ Communications Distance Specifications (Certified Performance)

Amplifier	Antenna	ID Tag	Communications Distance	
V680-HA63B	V680-HS52	V680-D2KF67M with metal on back surface (steel)	Read	0 to 16.0 mm (Axis offset: ± 2)
			Write	0 to 16.0 mm (Axis offset: ± 2)
	V680-HS63	V680-D2KF67M with metal on back surface (steel)	Read	6.0 to 25.0 mm (Axis offset: ± 10)
			Write	6.0 to 25.0 mm (Axis offset: ± 10)

• Measurement Conditions

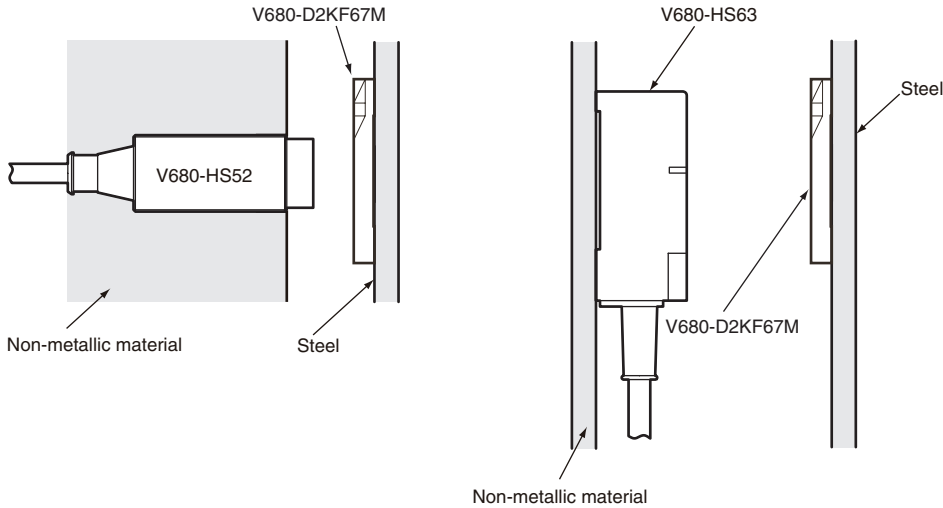

■ Communications Area (Reference)

- V680-HS52 & V680-D2KF67M
with Metal on Back Surface (Steel)
- Read/Write

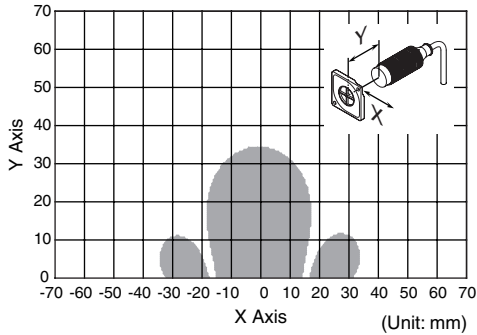

- V680-HS63 & V680-D2KF67M
with Metal on Back Surface (Steel)
- Read/Write

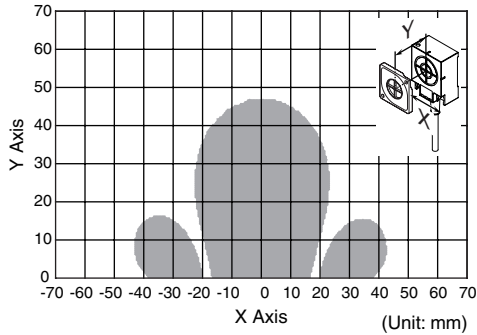

V680-D8KF68/-D32KF68

■ Communications Distance Specifications (Certified Performance)

Amplifier	Antenna	ID Tag	Communications Distance	
V680-HA63B	V680-HS63	V680-D8KF68	Read	0 to 45.0 mm (Axis offset: ± 10)
			Write	0 to 45.0 mm (Axis offset: ± 10)
		V680-D32KF68	Read	0 to 45.0 mm (Axis offset: ± 10)
			Write	0 to 45.0 mm (Axis offset: ± 10)

• Measurement Conditions

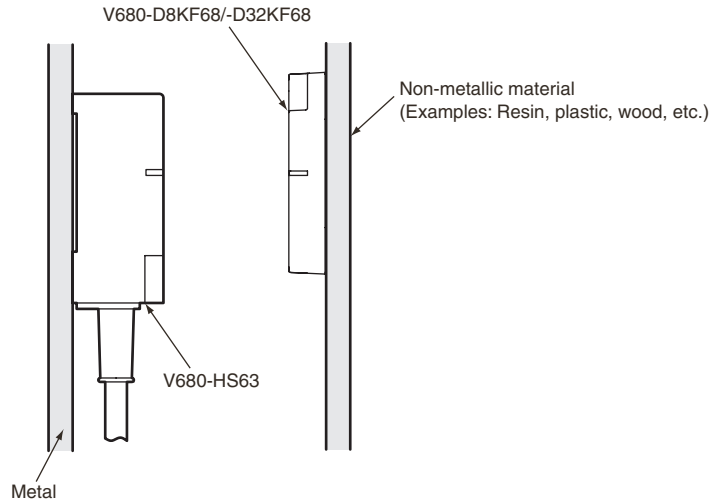

■ Communications Area (Reference)

- V680-HS63 and V680-D8KF68 or V680-D32KF68 (Horizontal-facing ID Tag)

▪ Read/Write

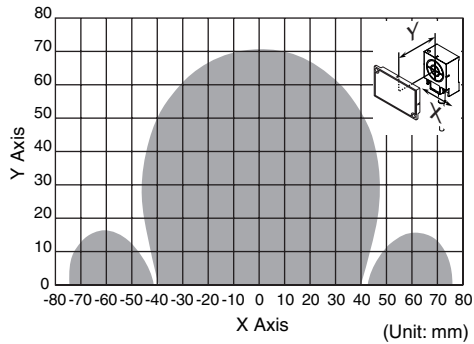

- V680-HS63 and V680-D8KF68 or V680-D32KF68 (Vertical-facing ID Tag)

▪ Read/Write

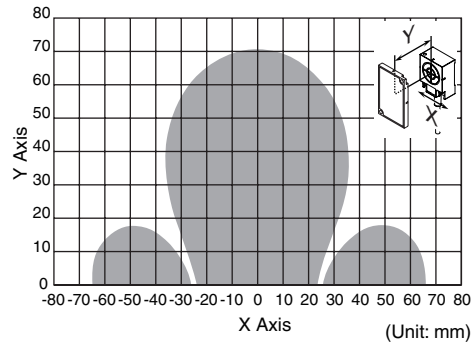

TAT and Communication Time (Reference)

TAT and Communications Time (Reference)

■ Communications Time

V680-HA63B, V680-HS@@, V680-D2KF@@

Communications speed setting	Command	Communications time N: No. of bytes processed
Normal mode	Read	$T = 1.2 N + 30$
	Write (with verification)	$T = 2.4 N + 49$
	Write (without verification)	$T = 1.2 N + 49$
High-speed mode (See note.)	Read	$T = 0.9 N + 27$
	Write (with verification)	$T = 1.7 N + 49$
	Write (without verification)	$T = 0.9 N + 41$

Note:When using multi-access or FIFO communications options, normal-mode communications speed will be used regardless of the high-speed mode setting.

Communications speed: Normal mode

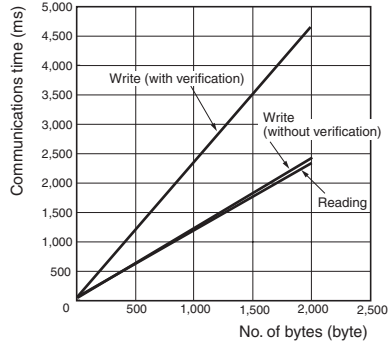

Communications speed: high-speed mode

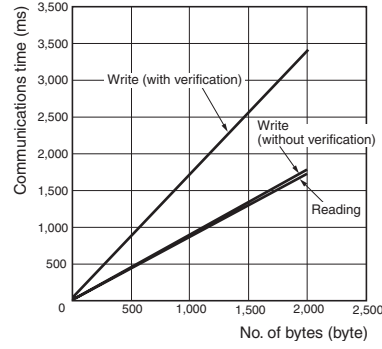

V680-HA63B, V680-HS@@, V680-D8KF@@, V680-D32KF@@

Communications speed setting	Command	Communications time N: No. of bytes processed
Normal mode	Read	$T = 1.3 N + 30$
	Write (with verification)	$T = 1.6 N + 59$
	Write (without verification)	$T = 1.3 N + 50$
High-speed mode (See note.)	Read	$T = 0.8 N + 25$
	Write (with verification)	$T = 1.1 N + 41$
	Write (without verification)	$T = 0.9 N + 40$

Note:When using multi-access or FIFO communications options, normal-mode communications speed will be used regardless of the high-speed mode setting.

Communications speed: Normal mode

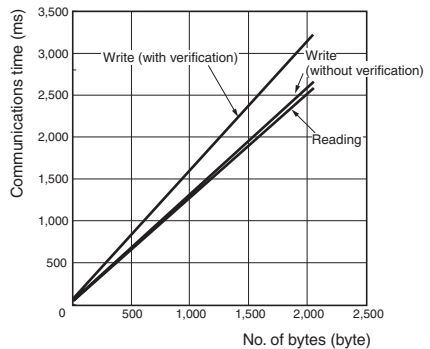

Communications speed: high-speed mode

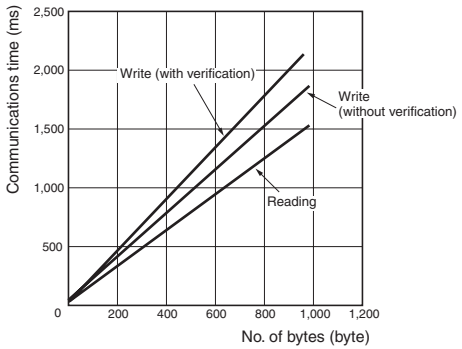

Section 3 TAT and Communication Time (Reference)

■ TAT (Turn Around Time)

“TAT” is the total time from the start of command transmission by the host device (e.g., a personal computer) until a response is received by the host device.

TAT = Command transmission time + Tag communications time + Response reception time

Command transmission time: The time required to send a command from the host device to the ID Controller. The command transmission time varies depending on the baud rate and the communications format.

Tag communications time: The processing time for communications between the Antenna and Tag.

Response reception time: The time required to return a response from the ID Controller to the host device. The response reception time varies depending on the baud rate and the communications format.

• Normal Commands

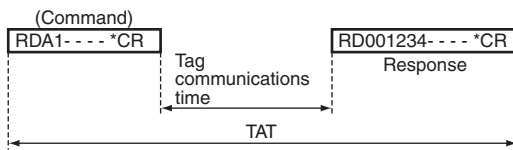

• EXPANSION READ Command

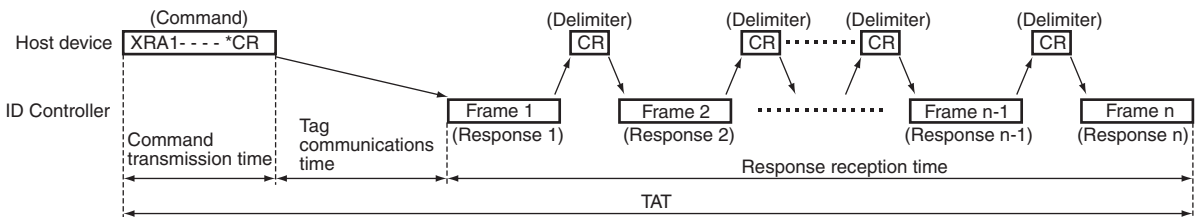

• EXPANSION WRITE Command

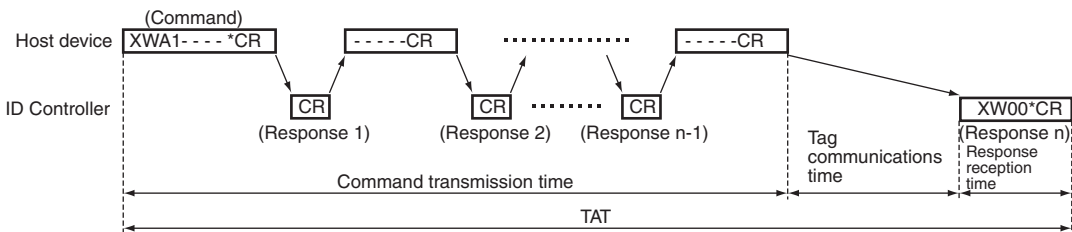

V680-HA63B, V680-HS@@, V680-D2KF@@

Conditions	No. of bytes processed (byte)	9,600 bps (ms)	19,200 bps (ms)	38,400 bps (ms)	115,200 bps (ms)
Read Communications speed Normal mode	100	291	220	185	162
	256	658	498	417	363
	512	1,259	951	798	695
	1,000	2,400	1,820	1,520	1,330
	2,000	4,760	3,590	3,020	2,620
Write With verification Communications speed Normal mode	100	430	359	324	301
	256	984	824	743	689
	512	1,892	1,584	1,431	1,328
	1,000	3,619	3,039	2,739	2,549
	2,000	7,139	4,849	5,439	5,039
Write Without verification Communications speed Normal mode	100	310	239	204	181
	256	677	517	436	382
	512	1,278	970	817	714
	1,000	2,419	1,839	1,539	1,349
	2,000	4,779	2,449	3,039	2,639
Read (See note. 1) Communications speed High-speed mode	100	261	190	155	132
	256	581	421	340	286
	512	1,105	797	644	541
	1,000	2,100	1,520	1,220	1,030
	2,000	4,160	1,830	2,420	2,020
Write (See note 1.) With verification Communications speed High-speed mode	100	360	289	254	231
	256	805	645	564	510
	512	1,534	1,226	1,073	970
	1,000	2,919	2,339	2,039	1,849
	2,000	5,779	3,449	4,039	3,639
Write (See note 1.) Without verification Communications speed High-speed mode	100	272	201	166	143
	256	592	432	351	297
	512	1,116	808	655	552
	1,000	2,111	1,531	1,231	1,041
	2,000	4,171	1,841	2,431	2,031

Note 1. When using multi-access or FIFO communications options, normal-mode communications speed will be used regardless of the high-speed mode setting.

2. TAT data is for a V680-CA5D01/02-V2 ID Controller with the following communications settings: 8-bit data length, 1 stop bit, and odd parity. Data was sent continuously without breaks between characters.
3. The number of bytes for TAT data is when the code designation is set to ASCII.

V680-HA63B, V680-HS@@, V680-D8KF@@, V680-D32KF@@

Conditions	No. of bytes processed (byte)	9,600 bps (ms)	19,200 bps (ms)	38,400 bps (ms)	115,200 bps (ms)
Read Communications speed Normal mode	100	301	230	195	172
	256	683	523	442	388
	512	1,310	1,002	849	746
	1,000	2,500	1,920	1,620	1,430
	2,000	4,960	2,630	3,220	2,820
Write With verification Communications speed Normal mode	100	360	289	254	231
	256	789	629	548	494
	512	1,493	1,185	1,032	929
	1,000	2,829	2,249	1,949	1,759
	2,000	5,589	3,259	3,849	3,449
Write Without verification Communications speed Normal mode	100	321	250	215	192
	256	703	543	462	408
	512	1,330	1,022	889	766
	1,000	2,520	1,940	1,640	1,450
	2,000	4,980	2,650	3,240	2,840
Read (See note 1.) Communications speed High-speed mode	100	246	175	140	117
	256	550	390	309	255
	512	1,049	741	588	485
	1,000	1,995	1,415	1,115	925
	2,000	3,955	1,625	2,215	1,815
Write (See note 1.) With verification Communications speed High-speed mode	100	292	221	186	163
	256	643	483	402	348
	512	1,219	911	758	655
	1,000	2,311	1,731	1,431	1,241
	2,000	4,571	2,241	2,831	2,431
Write (See note 1.) Without verification Communications speed High-speed mode	100	271	200	165	142
	256	591	431	350	296
	512	1,115	807	654	551
	1,000	2,110	1,530	1,230	1,040
	2,000	4,170	1,840	2,430	2,030

- Note 1.** When using multi-access or FIFO communications options, normal-mode communications speed will be used regardless of the high-speed mode setting.
- TAT data is for a V680-CA5D01/02-V2 ID Controller with the following communications settings: 8-bit data length, 1 stop bit, and odd parity. Data was sent continuously without breaks between characters.
 - The number of bytes for TAT data is when the code designation is set to ASCII.

Calculating Tag Speed

When communicating with a moving Tag, specify an AUTO command or POLLING command. The maximum speed for communicating with the Tag can be calculated simply using the following formula.

$$\text{Maximum speed} = \frac{D \text{ (Distance travelled in communications area)}}{T \text{ (Communications time)}}$$

D (Distance travelled in communications area) is calculated from the actual measurement or the communications area between the Antenna and Tag.

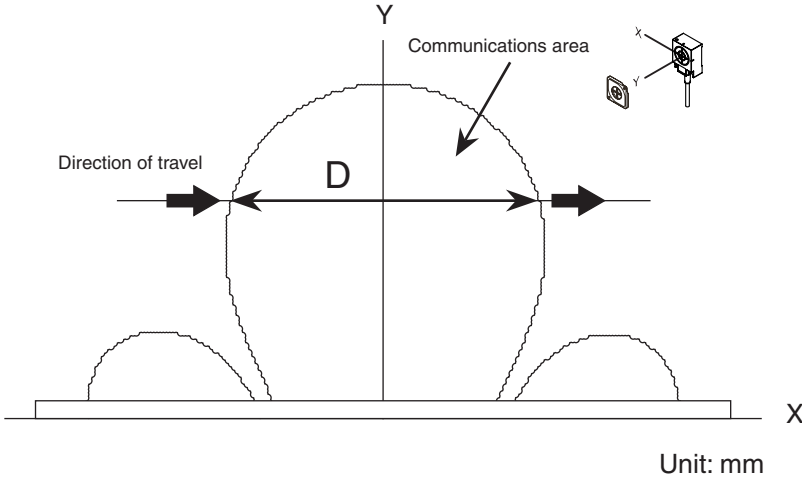

Calculation Example

In this example diagram, the V680-D2KF67, V680-HA63B, and V680-HS63 are combined and 256 bytes are read.

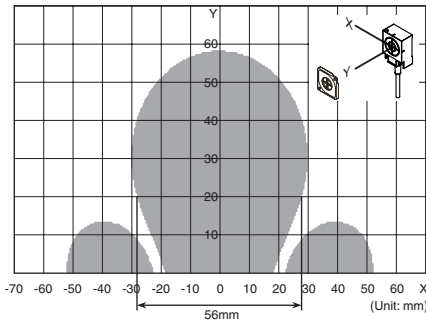

This diagram shows the following:
Distance travelled in communications area (D) = 56 mm when Y (communications distance) = 20 mm
Communications time, T = 317 ms.

Accordingly, the movement speed in this case will be as follows:

$$\frac{\text{Distance travelled in communications area}}{\text{Communications time}} = \frac{56 \text{ (mm)}}{317 \text{ (ms)}} = 10.60 \text{ m/min}$$

- Note**
1. The distance travelled in the communications area depends on the read/write distance and the axis offset. Refer to the diagrams in *Communications Area*.
 2. The speed of the Tag is provided as a guideline. Before using the RFID System, run a test to determine the speed under actual operating conditions.
 3. The above values do not take into account the processing of errors in communications with the host device or Tags.

MEMO

Section 4 Installation

☒ Installing Antennas	42
☒ Mounting Amplifiers	45
☒ Installing Tags	47

Installing Antennas

V680-HS63

Installation from the Front

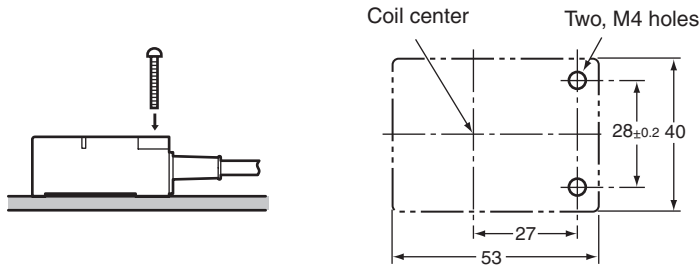

Installation from the Back

Insert the nuts that come with the Antenna into sections A.

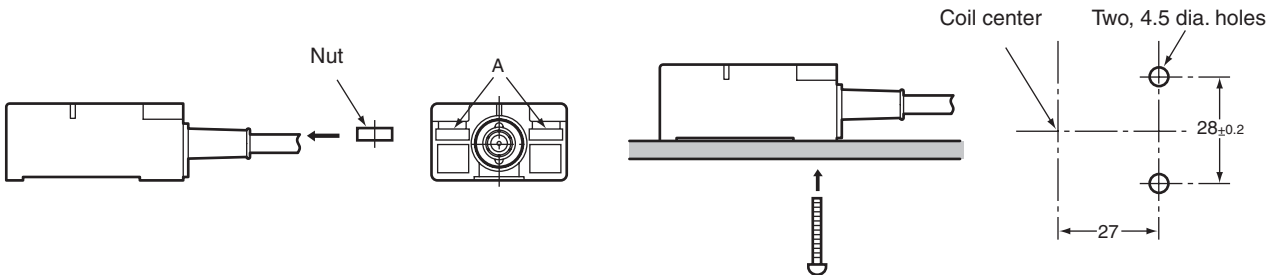

Securely tighten screws to a maximum torque of 1.2 N-m.

CHECK!

V680-HS52

Install the Antenna using the nuts and toothed washers that are provided on both sides of the mounting material, as shown in the diagram below.



When the Antenna is mounted to a metal object, the communications distance will be reduced by approximately 10% compared with mounting to a non-metallic object. For details on the effect of metal surrounding the Antenna, refer to *Effect of Surrounding Metals on the Antenna (Reference)* on page 43.

CHECK!



P.43

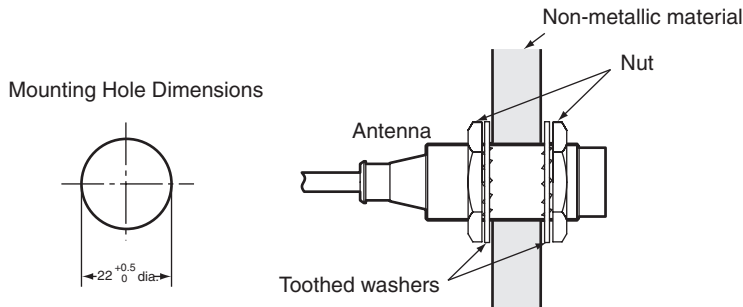

Securely tighten the screws to a maximum torque of 40 N-m.

CHECK!

Effect of Surrounding Metals on the Antenna (Reference)

■ V680-HS63

In addition to surface mounting, it is also possible to embed the V680-HS63 in a metal casing to protect it from being struck by other objects. To prevent malfunctioning, allow a space of at least 30 mm between the Antenna and the sides of the metal casing. If the space is less than 30 mm, the read/write distance will be greatly diminished. In addition, the height of metal casing must not exceed that of the Antenna.

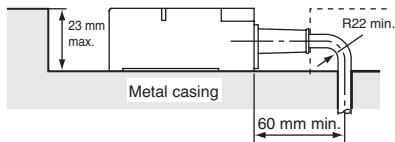

- Note**
1. Do not bend the cable into a curve tighter than 22 mm in radius.
 2. The communications distance will be reduced significantly if the Antenna is installed closer than 30 mm to metal surfaces.

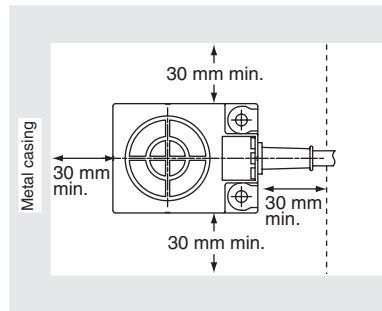

■ V680-HS52

When embedding the Antenna in metal, be sure the metal does not extend beyond the tip of the Antenna.

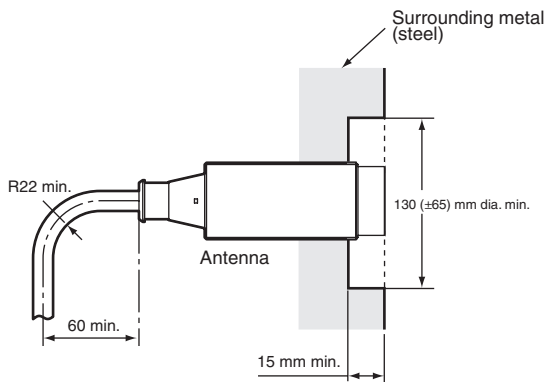

Do not bend the cable into a curve tighter than 22 mm in radius.

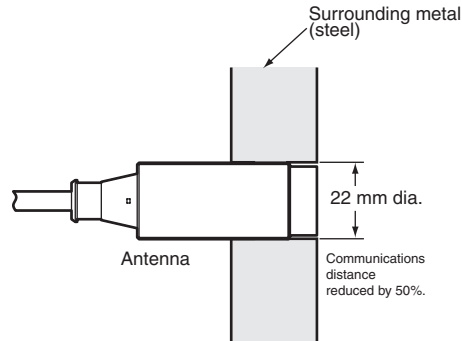

If the metal around the Antenna reaches the coil surface, the communications distance will be reduced significantly compared with mounting to a non-metallic surface.

Mutual Interference between Antennas (Reference)

To prevent malfunctioning due to mutual interference when using more than one Antenna, leave sufficient space between them as shown in the following diagrams.

■ V680-HS63

- Installing the Antennas Facing Each Other



- Installing the Antennas in Parallel

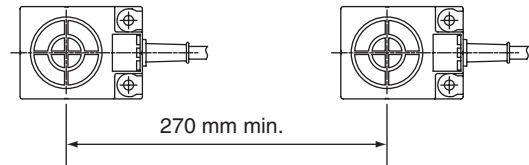

■ V680-HS52

- Installing the Antennas Facing Each

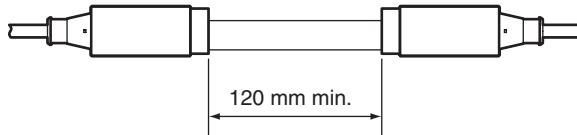

- Installing the Antennas in Parallel

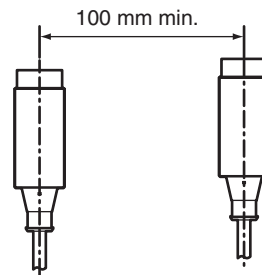

Mounting Amplifiers

V680-HA63B

■ Mounting to DIN Track

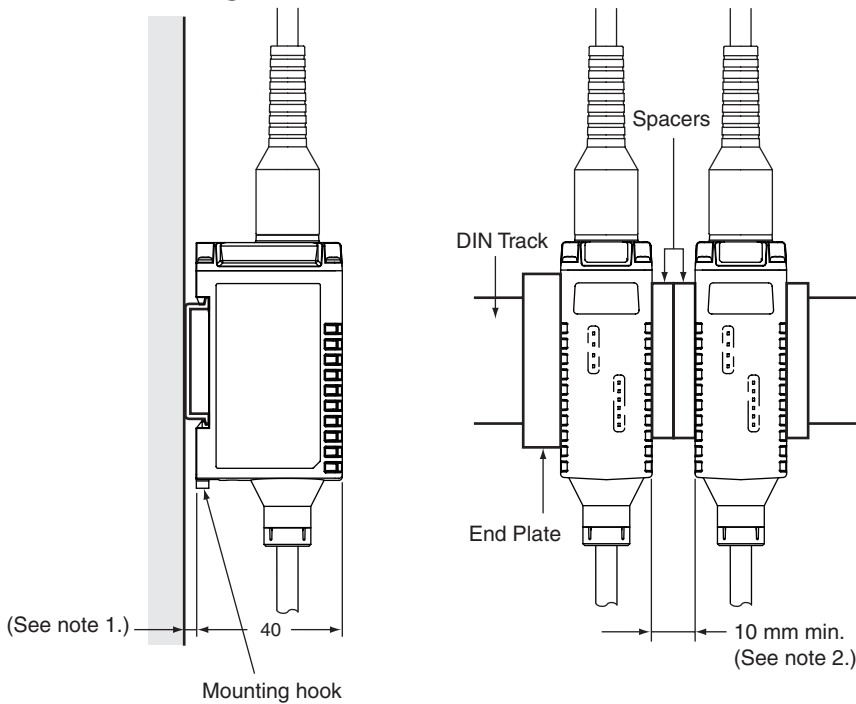

- Note** 1. Consider the height of the DIN Track.
 2. Provide a space of at least 10 mm (i.e., at least two spacers) and attach them securely.

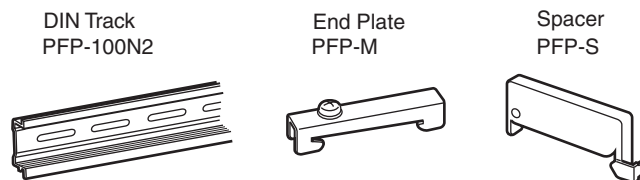
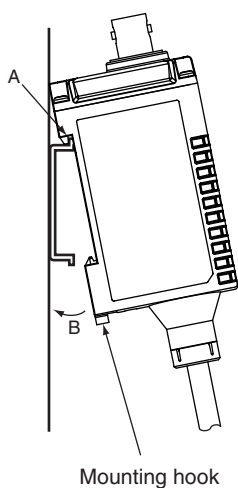

1. When mounting the Amplifier to a DIN Track, first hook section A to the Track and then press in direction B.
2. To remove the Amplifier from the DIN Track, first pull out the mounting hook.

Amplifier Cable Bending Radius

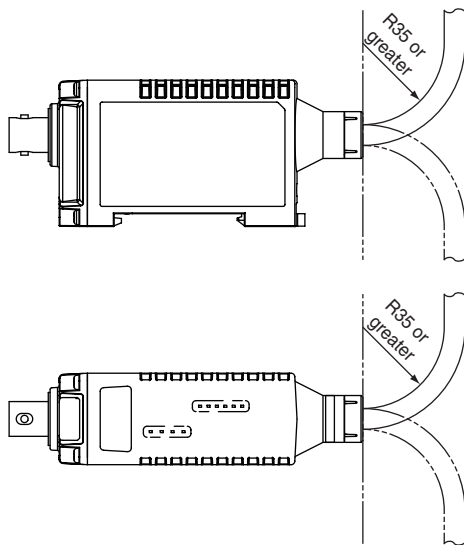

Do not bend the cable past a bending radius of 35 mm.

Attaching/Removing V680-HA63B/-HS63/-HS52 Connectors

■ Attaching the Connector

1. Hold the Antenna connector, align the key, and insert the connector into the Amplifier connector.
2. Turn the connector clockwise to lock it in place.

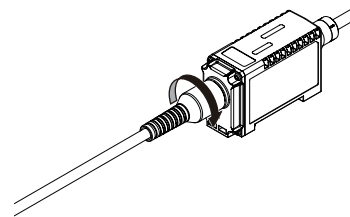
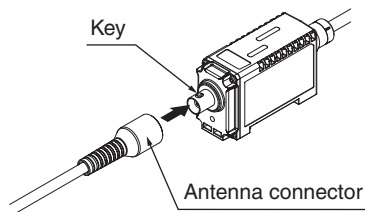

■ Removing the Connector

1. Turn the connector counterclockwise to release the lock.
2. Pull the Antenna connector straight out.

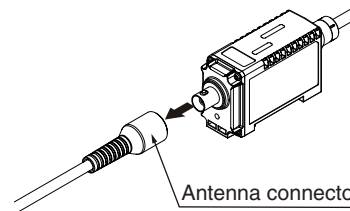
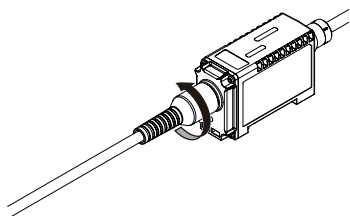

CHECK!

The connector will not come out unless the lock is first released by turning the connector. To remove the cable, release the lock and pull on the connector. Pulling the cable without releasing the lock may break or damage the cable.

Installing Tags

V680-D2KF52M

Tag Installation Direction

Mount Tags as shown in the diagram on the right.

The epoxy adhesives listed in the following table are recommended for the given temperature ranges.

Ambient operating temperature	Product name	Manufacturer
-40 to 70°C	Two-part Epoxy-compound Resin: TB2001 (main agent)/ TB2105C (curing agent)	Three Bond Co., Ltd.
	One-part Moisture-curing Elastic Adhesive TB1530	Three Bond Co., Ltd.
-40 to 85°C	One-part Epoxy Resin: TB2285	Three Bond Co., Ltd.
	Two-part Epoxy Resin: TB2087	Three Bond Co., Ltd.

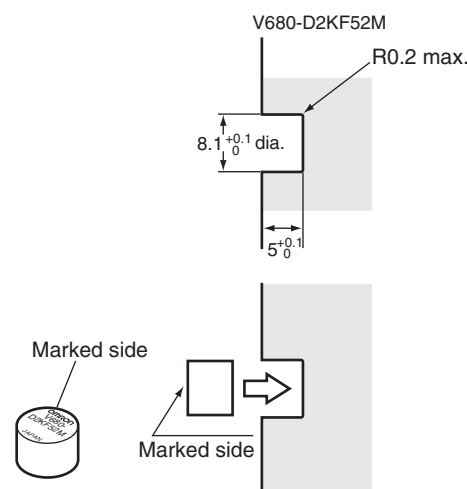

When embedding the V680-D2KF52M into a metal surface, use the V680-HS52 Antenna. Transmission will not be possible if the V680-HS63 Antenna is used.

CHECK!

Differences in Surrounding Metals

Communications distances are affected by the type of metal in back of or surrounding the Tag, as shown in the following table.

	Steel	SUS	Brass	Aluminum
V680-D2KF52M	100%	80% to 85%	80% to 85%	75% to 80%

The values for steel are set to 100%

Mutual Interference with Tags (Reference)

Provide the mounting distances indicated below to prevent malfunctions due to mutual interference when using more than one Tag.

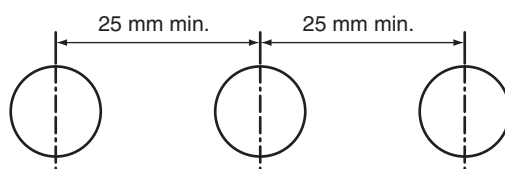

■ Influence of Angle (Reference)

Install Antennas and Tags as close to parallel to each other as possible. Communications are possible even when an Antenna and a Tag are mounted at an angle, but the communications distance will be shortened. The relation between the angle and the communications distance is shown below.

■ Percentage Drop in Communications Distance According to Angle of V680-D2KF52M

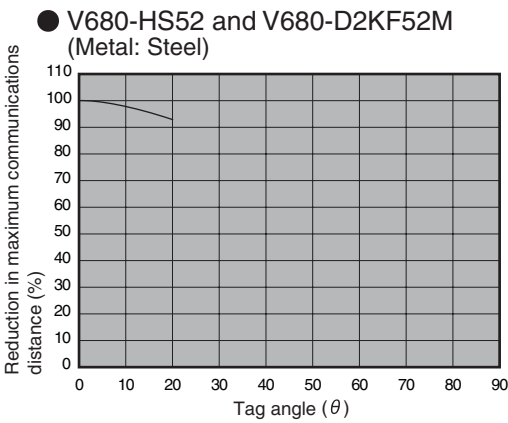
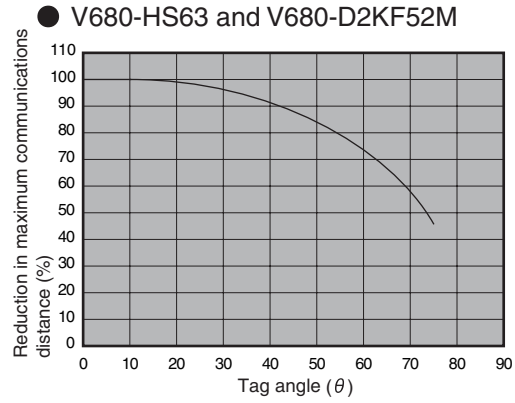
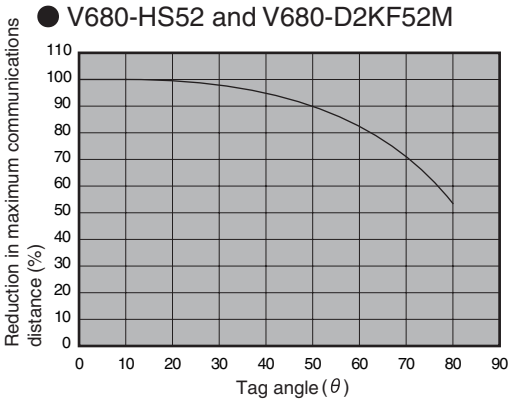

• V680-HS52 and V680-D2KF52M

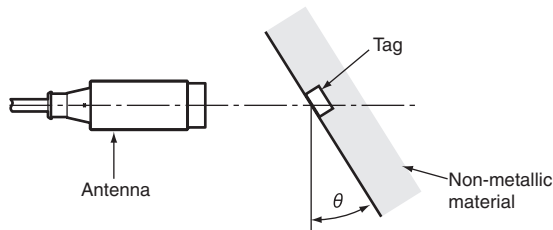

• V680-HS63 and V680-D2KF52M

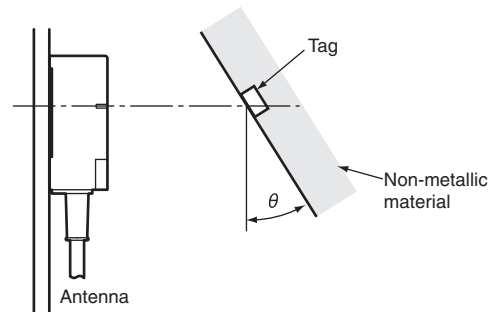

• V680-HS52 and V680-D2KF52M (Metal : Steel)

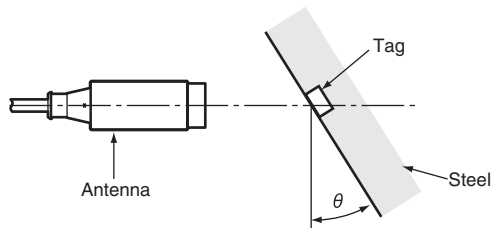

V680-D2KF67

Tag Installation Direction

Secure the Tag with M3 screws. Tighten the screws to a torque of 0.6 N·m or less.

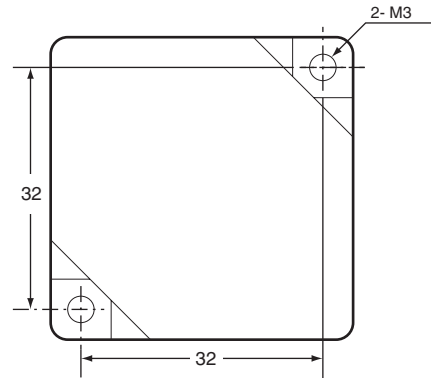

Effect of Metal behind Tags (Reference)

The V680-D2KF67 communications distance is reduced if there is any metal material behind the Tag.

● V680-HS52 and V680-D2KF67

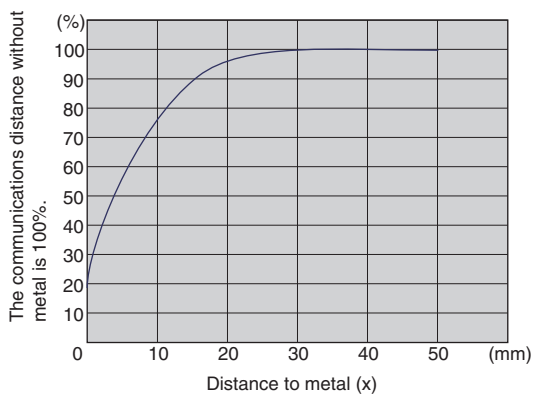

● V680-HS63 and V680-D2KF67

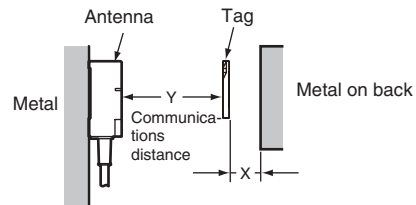
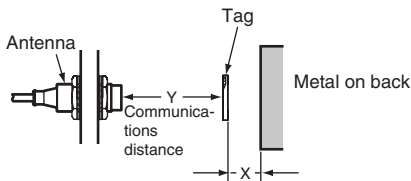
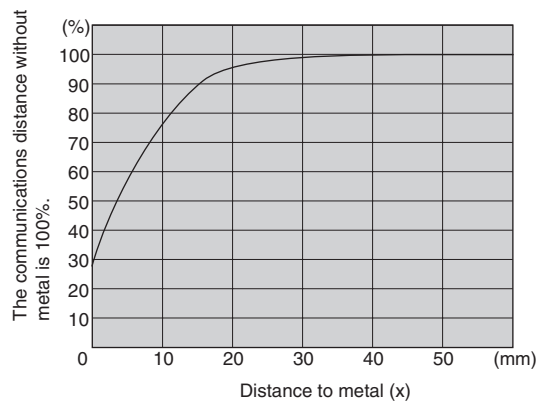

Mutual Interference with Tags (Reference)

To prevent malfunctioning due to mutual interference when using more than one Tag, leave sufficient space between them as shown in the following diagram.

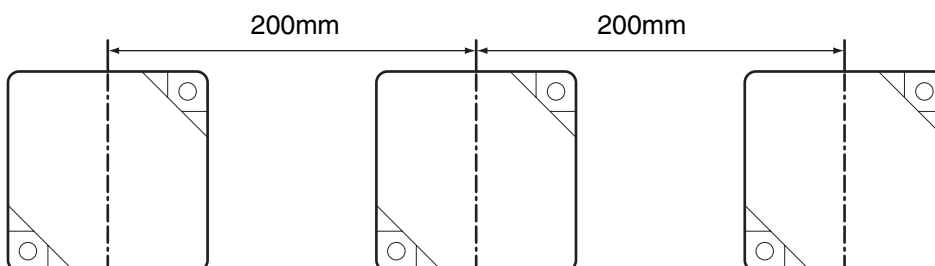

■ Influence of Tag Angle (Reference)

Install Antennas and Tags as close to parallel to each other as possible. Communications are possible even when an Antenna and a Tag are mounted at an angle, but the communications distance will be shortened. The relation between the angle and the communications distance is shown below.

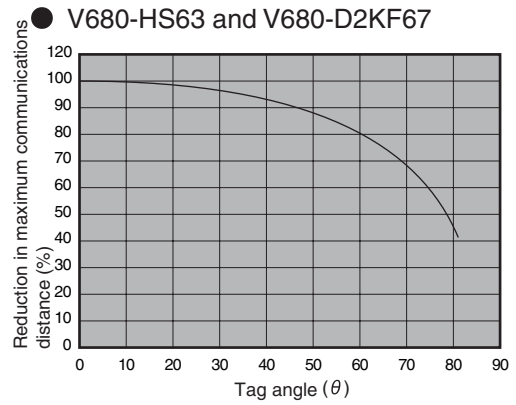
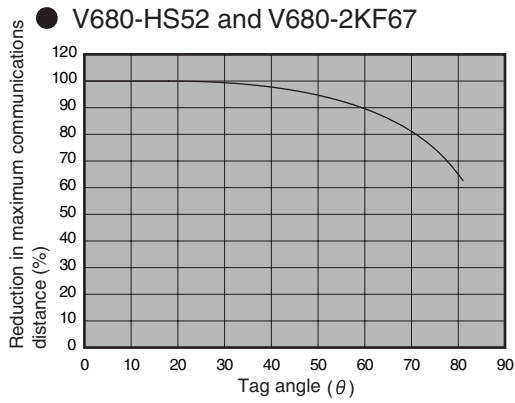

• V680-HS52 and V680-D2KF67

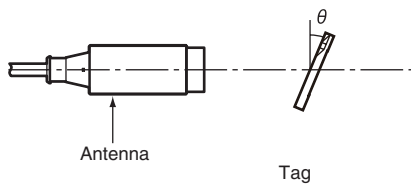

• V680-HS63 and V680-D2KF67

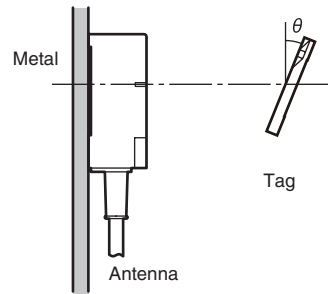

V680-D2KF67M

Tag Installation Direction

Mount the V680-D2KF67M to a metal surface, and secure the Tag with M3 screws. Tighten the screws to a torque of 0.6 N·m or less.

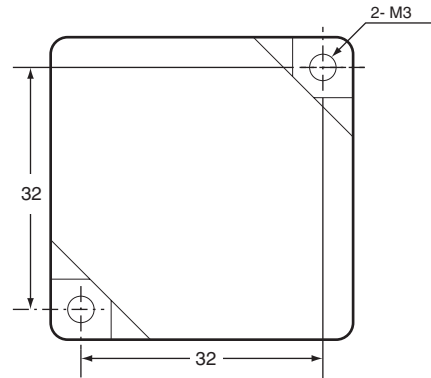

Effect of Surrounding Metals

The V680-D2KF67M can be surface-mounted or it can be embedded in metal. If it is embedded in metal, the height of the metal casing must not exceed that of the Tag.

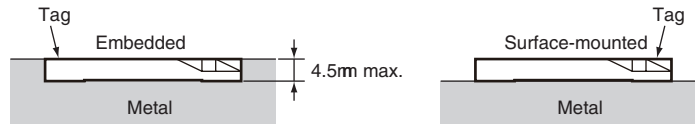

● V680-HS52 and V680-D2KF67M

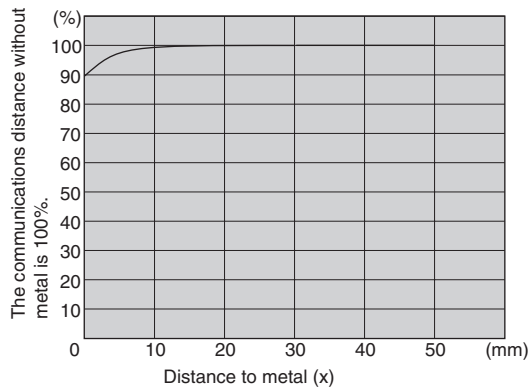

● V680-HS63 and V680-D2KF67M

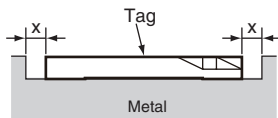
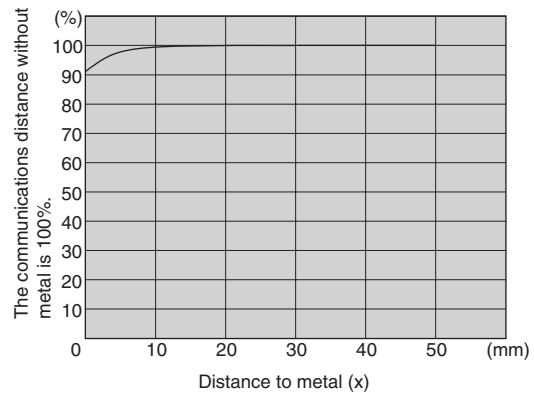

■ Mutual Interference with Tag (Reference)

To prevent malfunctioning due to mutual interference when using more than one Tag, leave sufficient space between them as shown in the following diagram.

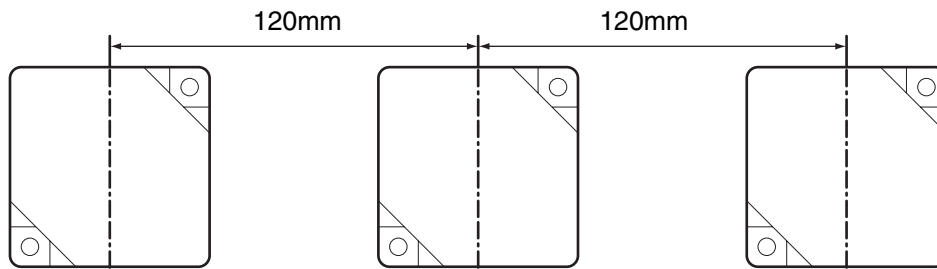

■ Influence of Tag Angle (Reference)

Install Antennas and Tags as close to parallel to each other as possible. Communications are possible even when an Antenna and a Tag are mounted at an angle, but the communications distance will be shortened. The relation between the angle and the communications distance is shown below.

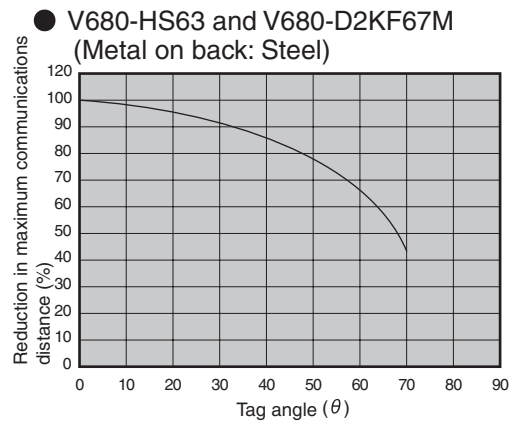
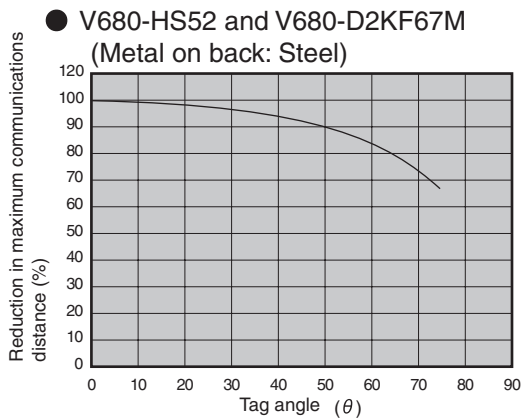

• V680-HS52 and V680-D2KF67M

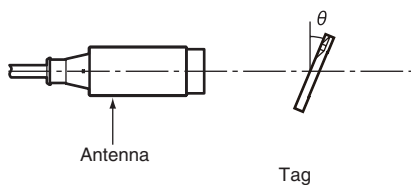

• V680-HS63 and V680-D2KF67M

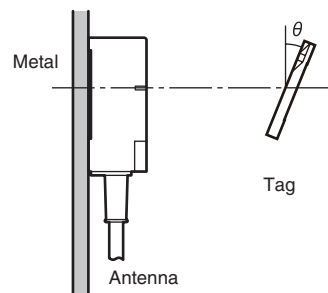

V680-D8KF68/-D32KF68

Tag Installation Direction

Secure the Tag with M4 screws. Tighten the screws to a torque of 0.7 to 1.2 N·m.

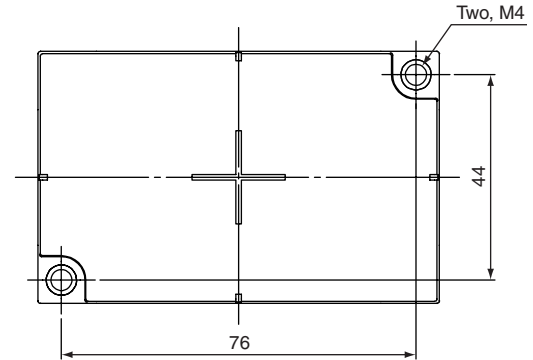

Effect of Metal behind Tags (Reference)

The communications distance for the V680-D8KF68 or V680-D32KF68 is reduced if there is any metal material behind the Tag.

● V680-HS63 & V680-D8KF68/-D32KF68

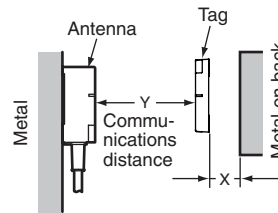
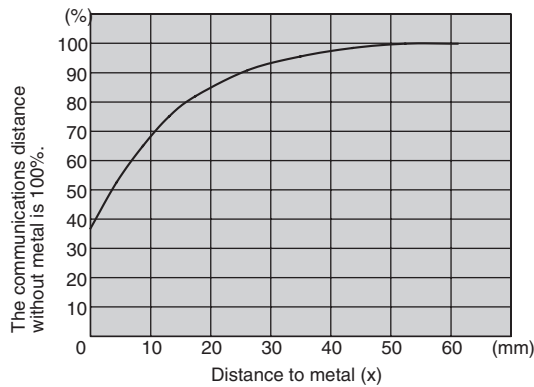

Mutual Interference with Tag (Reference)

To prevent malfunctioning due to mutual interference when using more than one Tag, leave sufficient space between them as shown in the following diagram.

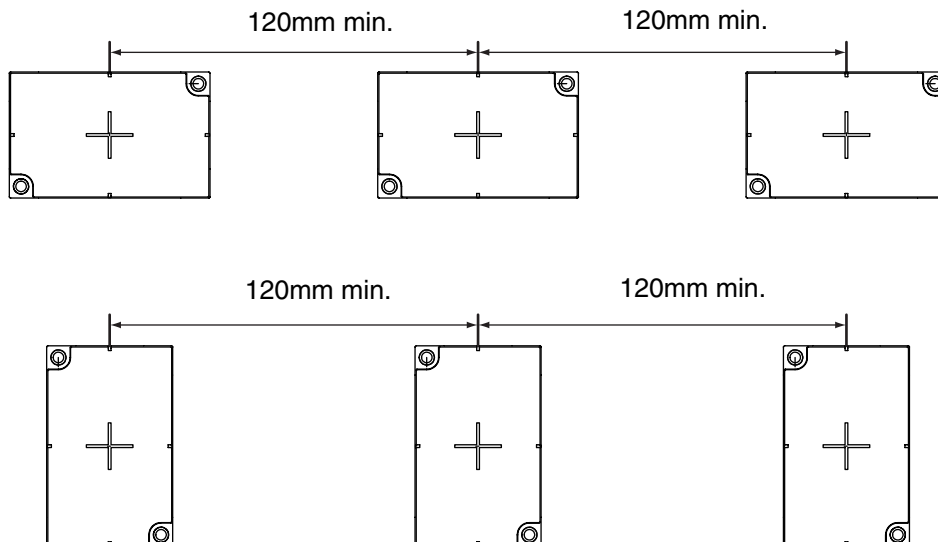

■ Influence of Tag Angle (Reference)

Install Antennas and Tags as close to parallel to each other as possible. Communications are possible even when an Antenna and a Tag are mounted at an angle, but the communications distance will be shortened. The relation between the angle and the communications distance is shown below.

- V680-HS63 and V680-D8KF68 or V680-D32KF68 (Horizontal-facing ID Tag)

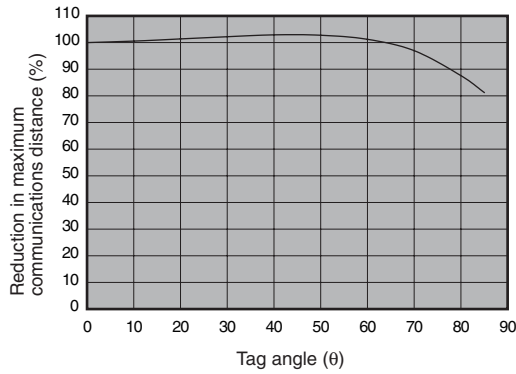

- V680-HS63 and V680-D8KF68, V680-D32KF68 (Vertical-facing ID Tag)

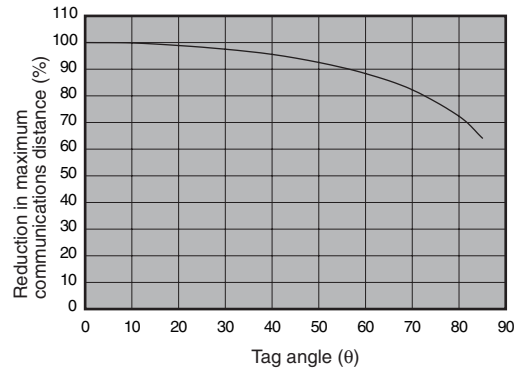

- V680-HS63 and V680-D8KF68 or V680-D32KF68 (Horizontal-facing ID Tag)

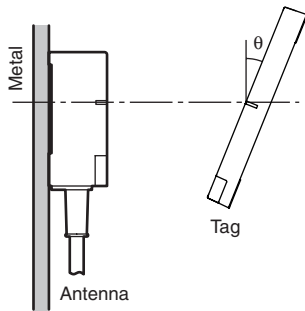

- V680-HS63 and V680-D8KF68, V680-D32KF68 (Vertical-facing ID Tag)

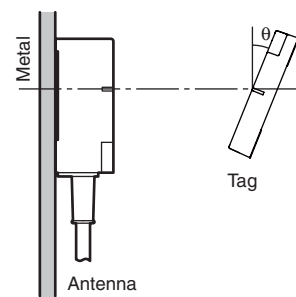

Section 5

Chemical Resistance

☒ Chemical Resistance of the Antennas	56
☒ Chemical Resistance of Tags	57
☒ Degree of Protection	60

Chemical Resistance of the Antennas

Applicable Models

V680-HS63-W/R V680-HS52-W/R

ABS resin is used for case material and epoxy resin for filling material. Refer to the following lists and do not use chemicals that affect ABS and epoxy resin.

Chemicals That Cause Deformations, Cracks, Etc.

ABS resin	Epoxy resin
Trichlene, acetone, xylene, toluene, gasoline, creosol, methylene chloride, phenol, cyclohexane, aqua regia, chromic acid, sulfuric acid (90% RT), methyl ethyl ketone, aniline, nitrobenzine, monochlorobenzine, pyridine, nitric acid (60% RT), formic acid (80% RT)	Aqua regia, chromic acid, sulfuric acid (90% RT), nitric acid (60% RT), ammonia solution, acetone, methylene chloride, phenol

Chemicals That May Cause Discoloration, Swelling, Etc.

ABS resin	Epoxy resin
Hydrochloric acid, alcohol, Freon, sodium hydroxide, hydrogen peroxide, benzine, sulfuric acid (10% RT), nitric acid (10% RT), phosphoric acid (85% RT), ammonia solution	Sulfuric acid (10% RT), nitric acid (10% RT), hydrochloric acid (30% RT), acetic acid (50% RT), oxalic acid, calcium hydroxide, benzine, creosol, alcohol, cyclohexane, toluene, xylene, benzine, grease

Chemicals That Do Not Affect ABS Resin or Epoxy Resin

ABS resin	Epoxy resin
Ammonia, kerosine, mineral oil, developer, Yushiroken S50, Chemi-Cool Z, Velocity No. 3, Yushiroken EEE-30Y, petroleum, grease, acetic acid, oxalic acid, calcium hydroxide, phosphoric acid (30% RT), hydrochloric acid (10% RT), potassium hydroxide	Ammonia, hydrochloric acid (10% RT), potassium hydroxide, petroleum, gasoline, Yushiroken S50, Chemi-Cool Z, Velocity No. 3, Yushiroken EEE-30Y

Note: The above results are from tests conducted at room temperature (23°C). Even if the chemicals do not affect the ABS or epoxy resins at room temperature, they may affect the resins at higher or lower temperatures. Check the chemicals carefully in advance.

Chemical Resistance of Tags

Applicable Models

V680-D2KF67/67M

Chemicals that affect Tags are shown below.

ABS resin is used for case material and epoxy resin for filling material. Refer to the following lists and do not use chemicals that affect ABS and epoxy resin.

Tags cannot be used in applications with explosion-proof specifications.

Chemicals That Cause Deformations, Cracks, Etc.

ABS resin	Epoxy resin
Trichlene, acetone, xylene, toluene, gasoline, creosol, methylene chloride, phenol, cyclohexane, aqua regia, chromic acid, sulfuric acid (90% RT), methyl ethyl ketone, aniline, nitrobenzine, monochlorobenzine, pyridine, nitric acid (60% RT), formic acid (80% RT)	Aqua regia, chromic acid, sulfuric acid (90% RT), nitric acid (60% RT), ammonia solution, acetone, methylene chloride, phenol

Chemicals That May Cause Discoloration, Swelling, Etc.

ABS resin	Epoxy resin
Hydrochloric acid, alcohol, Freon, sodium hydroxide, hydrogen peroxide, benzine, sulfuric acid (10% RT), nitric acid (10% RT), phosphoric acid (85% RT), ammonia solution	Sulfuric acid (10% RT), nitric acid (10% RT), hydrochloric acid (30% RT), acetic acid (50% RT), oxalic acid, calcium hydroxide, benzine, creosol, alcohol, cyclohexane, toluene, xylene, benzine, grease

Chemicals That Do Not Affect ABS Resin or Epoxy Resin

ABS resin	Epoxy resin
Ammonia, kerosine, mineral oil, developer, Yushiroken S50, Chemi-Cool Z, Velocity No. 3, Yushiroken EEE-30Y, petroleum, grease, acetic acid, oxalic acid, calcium hydroxide, phosphoric acid (30% RT), hydrochloric acid (10% RT), potassium hydroxide	Ammonia, hydrochloric acid (10% RT), potassium hydroxide, petroleum, gasoline, Yushiroken S50, Chemi-Cool Z, Velocity No. 3, Yushiroken EEE-30Y

Note: The above results are from tests conducted a room temperature (23°C). Even if the chemicals do not affect the ABS or epoxy resins at room temperature, they may affect the resins at higher or lower temperatures. Check the chemicals carefully in advance.

Applicable Model

V680-D2KF52M

PPS resin is used for case material and epoxy resin for filling material. Refer to the following lists and do not use chemicals that affect PPS and epoxy resin.

Tags cannot be used in applications with explosion-proof specifications.

Chemicals That Cause Deformations, Cracks, Etc.

PPS resin	Epoxy resin
Aqua regia	Aqua regia, chromic acid, sulfuric acid (90% RT), nitric acid (60% RT), ammonia solution, acetone, methylene chloride, phenol

Chemicals That May Cause Discoloration, Swelling, Etc.

PPS resin	Epoxy resin
Nitric acid (60% RT)	Sulfuric acid (10% RT), nitric acid (10% RT), hydrochloric acid (30% RT), acetic acid (50% RT), oxalic acid, calcium hydroxide, benzene, creosol, alcohol, cyclohexane, toluene, xylene, benzene, grease

Chemicals that Do Not Affect PPS Resin or Epoxy Resin

PPS resin	Epoxy resin
Hydrochloric acid (37%RT), sulfuric acid (98%RT), nitric acid (40%RT), Hydrogen fluoride solution (40%RT), chromic acid (40%RT), hydrogen peroxide (28%RT), sodium hydroxide solution (60%RT), ammonia solution (28%RT), sodium chloride (10%RT), sodium carbonate (20%RT), sodium hypochlorite, phenol solution (5%RT), glacial acetic acid, acetic acid, oleic acid, Methyl alcohol (95%RT), ethyl alcohol (95%RT), Ethyl acetate, sebacic acid, diethylhexyl, acetone, diethyl ether, n-heptane, 2-2-4 trimethylpentane, benzene, toluene, aniline, mineral oil, gasoline, insulating oil, dichloroethylene, carbon tetrachloride	Ammonia, hydrochloric acid (10% RT), potassium hydroxide, petroleum, gasoline, Yushiroken S50, Chemi-Cool Z, Velocity No. 3, Yushiroken EEE-30Y, methyl ethyl ketone, sodium hydroxide (10%RT)

Note: The above results are from tests conducted at room temperature (23°C). Even if the chemicals do not affect the PPS or epoxy resins at room temperature, they may affect the resins at higher or lower temperatures. Check the chemicals carefully in advance.

Applicable Model

V680-D8KF68/D32KF68

Chemicals that affect Tags are shown below.

Polybutylene terephthalate (PBT) resin is used for case material and epoxy resin for filling material. Refer to the following lists and do not use chemicals that affect PBT and epoxy resins.

Tags cannot be used in applications with explosion-proof specifications.

Chemicals That Cause Deformations, Cracks, Etc.

PBT resin	Epoxy resin
Acetone, trichloroethylene, ethylene dichloride, sodium hydroxide, and other alkaline substances	Aqua regia, chromic acid, sulfuric acid (90% RT), nitric acid (60% RT), liquid ammonia, acetone, methylene chloride, phenol

Chemicals That May Cause Discoloration, Swelling, Etc.

PBT resin	Epoxy resin
Hydrochloric acid (10% RT), acetic acid (5% RT), benzene	Sulfuric acid (10% RT), nitric acid (10% RT), concentrated hydrochloric acid, acetic acid (50% RT), nitric acid, calcium hydroxide, benzene, cresol, alcohol, microhexanon, toluene, xylene, benzene, grease

Chemicals that Do Not Affect PPS Resin or Epoxy Resin

PBT resin	Epoxy resin
Nitric acid (30% RT), concentrated hydrochloric acid, acetic acid, ethyl acetate (100% RT), potassium permanganate (5% RH), ethyl acetate, carbon tetrachloride, methanol, ethanol, gasoline	Ammonia, hydrochloric acid (10% RT), calcium hydroxide, petroleum, gasoline, Yushiroken S50, Chemi-cool Z, Velocity No. 3, Yushiroken EEE-30Y, methyl ethyl ketone, sodium hydroxide

Note: The above results are from tests conducted at room temperature (23°C). Even if the chemicals do not affect the PPS or epoxy resins at room temperature, they may affect the resins at higher or lower temperatures. Check the chemicals carefully in advance.

Degree of Protection

Ingress protection degrees (IP-@@) are determined by the following tests. Be sure to check the sealing capability under the actual operating environment and conditions before actual use.

IP indicates the ingress protection symbol.

■ IEC (International Electrotechnical Commission) Standards IEC 60529: 1989-11

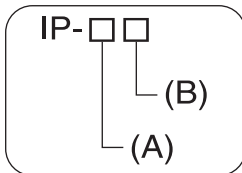









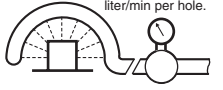

(A) First Digit: Degree of Protection from Solid Materials

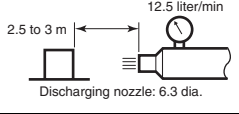
Degree	Degree	
0		No protection
1		Protects against penetration of any solid object such as a hand that is 50 mm or more in diameter.
2		Protects against penetration of any solid object, such as a finger, that is 12.5 mm or more in diameter.
3		Protects against penetration of any solid object, such as a wire, that is 2.5 mm or more in diameter.
4		Protects against penetration of any solid object, such as a wire, that is 1 mm or more in diameter.
5		Protects against penetration of dust of a quantity that may cause malfunction or obstruct the safe operation of the product.
6		Protects against penetration of all dust.

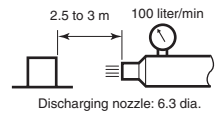
(B) Second Digit: Degree of Protection Against Water

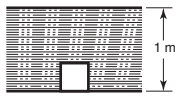
Degree	Protection		Test method (with pure water)
0	No protection	Not protected against water.	No test
1	Protection against water drops 	Protects against vertical drops of water towards the product.	Water is dropped vertically towards the product from the test machine for 10 min.
2	Protection against water drop 	Protects against drops of water approaching at a maximum angle of 15° to the left, right, back, and front from vertical towards the product.	Water is dropped for 2.5 min each (i.e., 10 min in total) towards the product inclined 15° to the left, right, back, and front from the test machine.

Degree	Protection	Test method (with pure water)
3	Protection against sprinkled water 	Protects against sprinkled water approaching at a maximum angle of 60° from vertical towards the product. Water is sprinkled for 10 min at a maximum angle of 60° to the left and right from vertical from the test machine.  Water rate is 0.07 liter/min per hole.
4	Protection against water spray 	Protects against water spray approaching at any angle towards the product. Water is sprayed at any angle towards the product for 10 min from the test machine.  Water rate is 0.07 liter/min per hole.
5	Protection against water jet spray 	Protects against water jet spray approaching at any angle towards the product. Water is jet sprayed at any angle towards the product for 1 min per square meter for at least 3 min in total from the test machine.  12.5 liter/min 2.5 to 3 m Discharging nozzle: 6.3 dia.
6	Protection against high pressure water jet spray 	Protects against high-pressure water jet spray approaching at any angle towards the product. Water is jet sprayed at any angle towards the product for 1 min per square meter for at least 3 min in total from the test machine.  2.5 to 3 m 100 liter/min Discharging nozzle: 6.3 dia.
7	Protection underwater 	Resists the penetration of water when the product is placed underwater at specified pressure for a specified time. The product is placed 1 m deep in water (if the product is 850 mm max. in height) for 30 min. 
8	Protection underwater 	Can be used continuously underwater. The test method is determined by the manufacturer and user.

■ Oil resistance (OMRON in-house standard)

Protection	
Oil-resistant	No adverse affect from oil drops or oil spray approaching from any direction.
Oil-proof	Protects against penetration of oil drops or oil spray approaching from any direction.

Note: This OMRON in-house standard confirms resistance to cutting and other oils. It is equivalent to the former JEM standard.

OMRON

OMRON Corporation
Industrial Automation Company

Sensing Devices Division H.Q.
Industrial Sensors Division

Shiokoji Horikawa, Shimogyo-ku,
Kyoto, 600-8530 Japan
Tel: (81)75-344-7022/Fax: (81)75-344-7107

Regional Headquarters

OMRON EUROPE B.V.

Sensor Business Unit
Carl-Benz-Str. 4, D-71154 Nufringen,
Germany
Tel: (49) 7032-811-0/Fax: (49) 7032-811-199

OMRON ELECTRONICS LLC

One Commerce Drive Schaumburg,
IL 60173-5302 U.S.A
Tel: (1) 847-843-7900/Fax: (1) 847-843-7787

OMRON ASIA PACIFIC PTE. LTD.

No. 438A Alexandra Road # 05-05/08 (Lobby 2),
Alexandra Technopark, Singapore 119967
Tel: (65) 6835-3011/Fax: (65) 6835-2711

OMRON (CHINA) CO., LTD.

Room 2211, Bank of China Tower,
200 Yin Cheng Zhong Road,
Pu Dong New Area, Shanghai, 200120, China
Tel: (86) 21-5037-2222/Fax: (86) 21-5037-2200

In the interest of product improvement, specifications are
subject to change without notice.

Authorized Distributor: